



SWITCHGEARS FOR TUNNELS AND DEPOTS

■ METRO ■

ABOUT COMPANY

PLUTON is one of the largest manufacturers of electrotechnical equipment on the territory of Europe. The company's products are supplied to many countries around the world. PLUTON holds key position in electrical industry and has been successfully working for over 25 years, realizing the strategy of intensive growth, development and continuous improvement of products quality and services.

The company confirmed compliance of its management principles with quality management system international standard ISO 9001:2015, Environmental Safety ISO 14001:2015, as well as occupational safety and health OHSAS 18001:2007 requirements.

Due to vast experience and modern technologies we make secure, reliable and efficient energy distribution. We are building future, creating products of up- to-date level in compliance with international standards, innovative technologies that ensure safety and comfort of people.



SWITCHGEARS SERIES RU-825 FOR TUNNELS AND DEPOT

Switchgears are applied in metro depot and tunnels for reception and distribution of power with rated voltage 825 V.

Distinctive features:

- high reliability;
- small overall dimensions and weight;
- serviceability;
- minimum expenditure of servicing time;
- minimum probability of fire occurrence.

RU-825LR, RU-825PK, RU-825ZK, RU-825PP are manufactured as a separate metal cabinets with one-side servicing.

RU-825PR, RU-825SR and RU-825RS are manufactured as complete devices, consisting of several connected metal cabinets.

Structural elements produced by RITTAL (Germany), as well as components of world's leading manufacturers: ABB, Schneider Electric, Weidmuller, etc., are used in switchgear manufacturing.



TYPES AND COMPOSITION OF SWITCHGEARS FOR TUNNELS AND DEPOT:

Name of switchgear		Main component
RU-825LR	with line disconnector	line disconnector
RU-825PK	cables connection	copper bus bar, for feeding circuit connection to contact rail; potential balancing bus bar
RU-825PR	contact rail feeding	feeding circuits switching disconnectors
RU-825ZK	with short-circuiting contactor	contactor for track rail insulated joint short-circuiting
RU-825RS	distribution and sectioning	input disconnector of +825 V circuit with double break; four input disconnectors with double break
RU-825SR	sectioning with disconnectors switching with disconnectors	disconnector of +825 V circuit; disconnector of minus 825 V circuit
RU-825PP	switching with disconnectors	disconnector of +825 V circuit with double break

RU-825PK SWITCHGEAR (CABLES CONNECTION)



Switchgears RU-825PK are applied at DC metro traction networks with voltage 825 V as cabinets for cables connection in tunnel and depot.

Structurally RU-825PK consists of one-side serviced cabinet and foundation. The cabinet is equipped with power bus bars to which cables are connected.

The bus bars go through the bottom for connection to contact rail. Frames for cables mechanical fixing are installed on the side of the cabinet. The foundation is provided for cabinet installation on proper location.

The cabinets are manufactured both for outdoor installation (in depot) and for indoor installation (in tunnel).

TECHNICAL DETAILS RU-825PK

Name of parameter	Unit	Value
Rated voltage of power circuit	V	825
Rated current of power circuit	A	4000
Testing voltage	kV	24
Protection class	-	IP 33
Number of connected cables section 625 mm ²	units	4
Modification: RU-825PK-L RU-825PK-P	-	Left Right
Overall dimensions, max.	mm	500 x 1660 x 810
Weight, max.	kg	70

SINGLE-LINE DIAGRAM RU-825PK

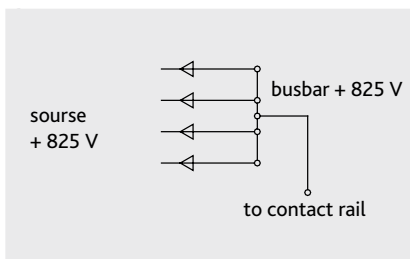

OVERALL DIMENSIONS RU-825PK

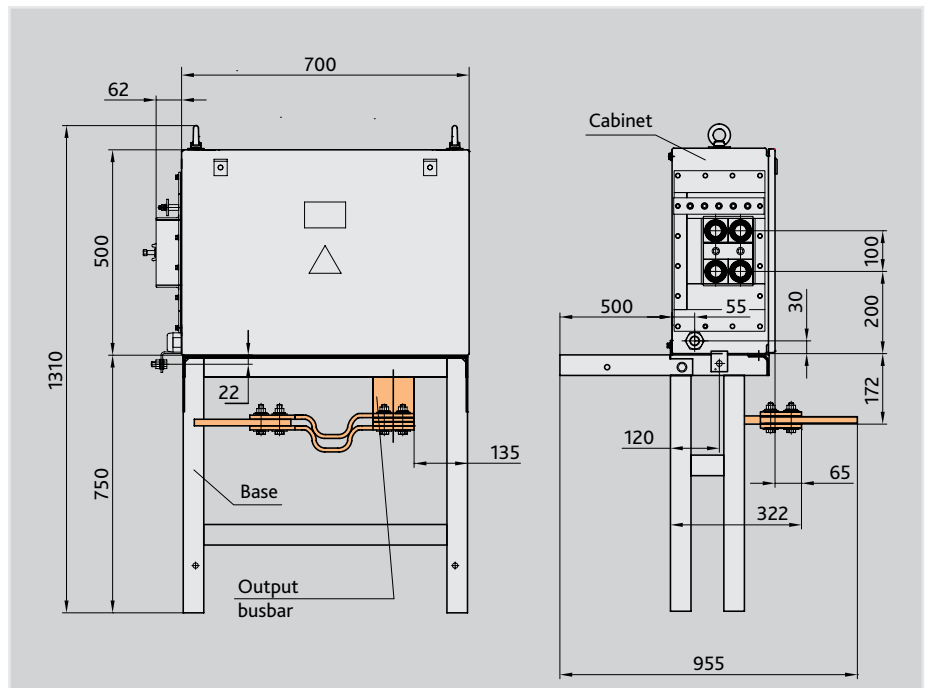

RU-825LR SWITCHGEAR (WITH LINE DISCONNECTOR)



SINGLE-LINE DIAGRAM RU-825LR

Pressure seals provide high sealing level in conditions of equipment operation in metro tunnels.

Connection of power bus bar to disconnector is done from below through a hole in insulation panel installed on the bottom. There is a possibility of disconnector drive control in local or remote modes.

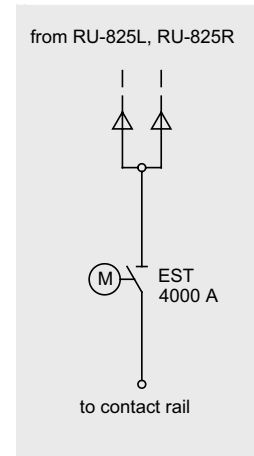

TECHNICAL DETAILS RU-825LR

RU-825LR switchgears are provided for closing and opening of metro contact rail 825 V dead parts in tunnel and depot. They provide supply line 825 V switching with rated current 4000 A.

They consist of two compartments:

- compartment with disconnector and power jumper;
- control and disconnector drive compartment.

Overview window for visual observation of disconnector operation is on control compartment door. A small cabinet with disconnector control buttons and lighting switch is installed in the top part of the door. The cabinet is equipped with a door with locks in form of free key-handle.

There are several modifications of cabinets depending on number and location of connected power cables and bus bars at input and output.

Connection of power cables to disconnector is done via cable clamps and special marine pressure seals.

Name of parameter	Unit	Value
Disconnector type	-	EST 4000
Rated voltage of power circuit	V	825
Rated current of power circuit	A	4000
Dynamic stability current	kA	100
Electric drive signaling and control circuits voltage (DC)	V	220
Lighting circuits voltage (50 Hz)	V	12
RU-825LR casing protection class (except places of bus bars outgoing to contact rail)	-	IP54
Cyclicality (closing or opening)	hourly	40
Mechanical stability, min	cycles	30000
Weight, max.	kg	175

OVERALL DIMENSIONS RU-825LR

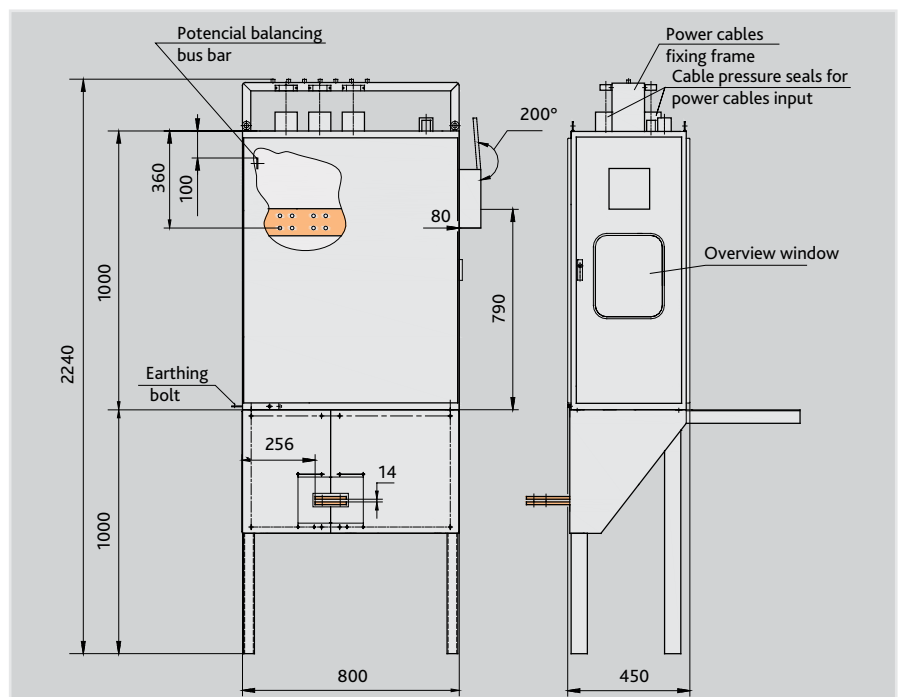

RU-825PR SWITCHGEAR (CONTACT RAIL FEEDING)

Contact rail feeding switchgears are applied for dead-end siding with and without ditch contact rail feeding, for commuting of main-line track orifice plate circuit - dead-end siding orifice plate (maintenance inspection track section). They power provide supply and distribution with voltage 825 V and rated current 4000 A.

Cabinets represent double-side serviced three-compartment complete device, including power devices for power distribution (automatic and manual control), control, indication, signaling and protection system.

Disconnectors power bus bars and commuting power part are separated from control zone with mounting panels. There are overview windows on front doors for disconnectors position visual observation.

Connection of power cables to disconnector is provided from the top through cable clamps and special marine pressure seals installed on the roof.



SINGLE-LINE DIAGRAM RU-825PR

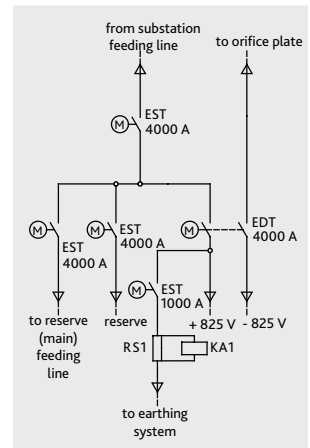

TECHNICAL DETAILS RU-825PR

Name of parameter	Unit	Value
Disconnector type	-	EST 4000, EDT 4000, EST 1000
Rated voltage of power circuit	V	825
Rated current of power circuit	A	4000
Rated current of "minus 825 V" circuit disconnector and earthing disconnector	A	1000
Light signaling circuits voltage (50 Hz)	V	220
Motor drive control circuits voltage, DC	V	220
Lighting circuits voltage (50 Hz)	V	220/12
Protection class	-	IP54
Cyclicality (closing or opening of disconnector with motor drive)	hourly	20
Mechanical stability	cycles	20000
Overall dimensions without base, max	mm	2400 x 2000* x 800

OVERALL DIMENSIONS RU-825PR

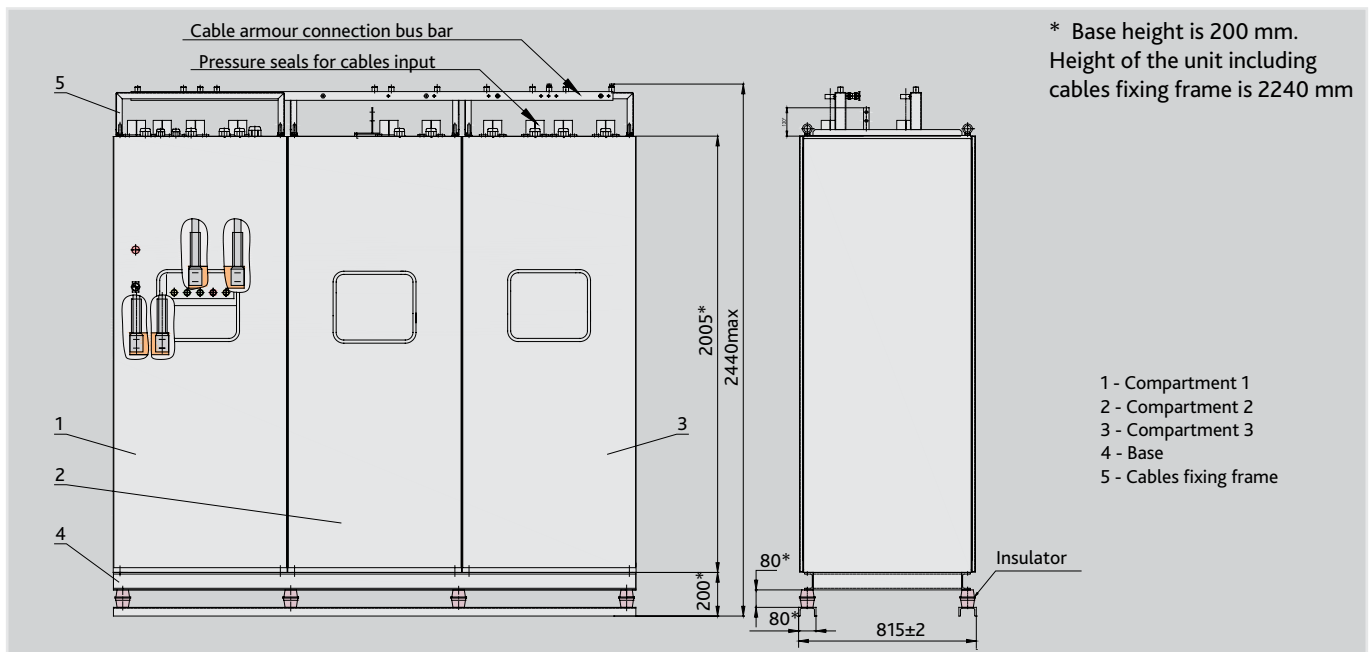

RU-825ZK SWITCHGEAR (WITH SHORT-CIRCUITING CONTACTOR)

The unit is provided for automatic short-circuiting of track rail insulated joint (rolling stock maintenance inspection track section) during voltage supply to metro line contact rail.

RU-825ZK is a one-side serviced complete device, including contactor, protection and lighting devices.

Structurally RU-825ZK consists of a cabinet and base. Power contactor and control elements are installed in the cabinet.

Base is provided for cabinet installation on its proper location. Power cables are ingoing into the cabinet from below.

Switching of contactor is done automatically in case of voltage supply from substation feeding line to contact line of rolling stock maintenance inspection track section. Connection of contactor to control system is provided with double-pole automatic circuit-breaker. Power supply to contactor coil is 220 V, 50 Hz.

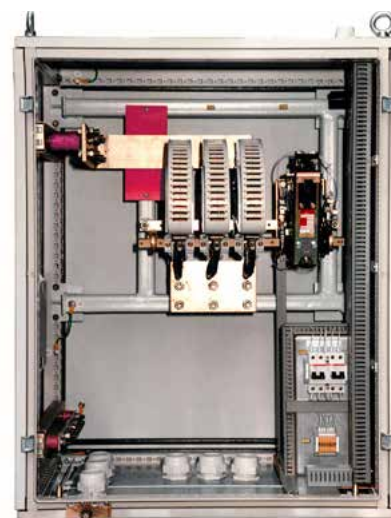

TECHNICAL DETAILS RU-825ZK

Name of parameter	Unit	Value
Rated voltage of power circuit	V	400
Rated current of power circuit	A	400, 1000
Contactor control circuits voltage (50 Hz)	V	220
Lighting circuits voltage (50 Hz)	V	12
Cyclicality (closing-opening)	hourly	10
Mechanical stability (no-load), min	cycles	100000
Protection class	-	IP54
Overall dimensions	mm	800 x 1000* x 450

* Base height 1000 mm.

OVERALL DIMENSIONS RU-825ZK

SINGLE-LINE DIAGRAM RU-825ZK

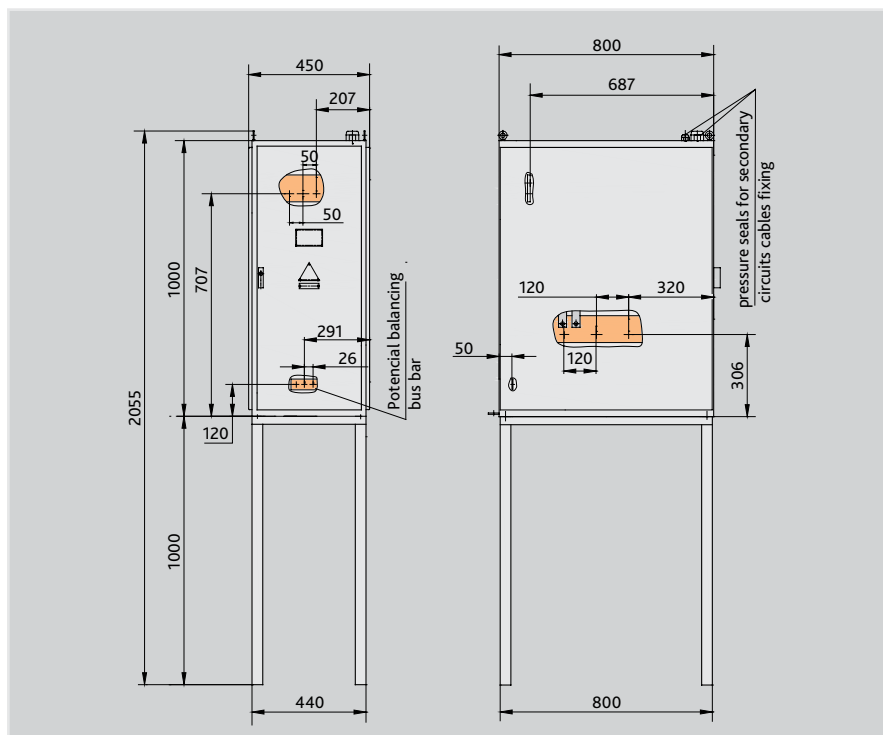
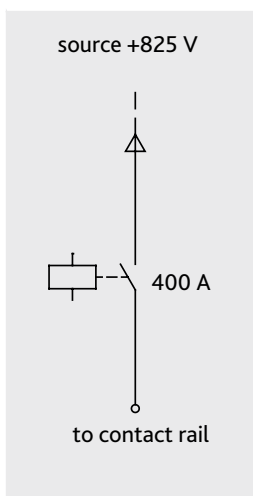

RU-825RS SWITCHGEAR (DISTRIBUTION AND SECTIONING)

Structurally RU-825RS is made as one-side services metal cabinet, divided into five compartments. Switchgear RU-825RS is provided for operation in metro depot traction network as a device for switching of third rails power supply circuits.

Each compartment is equipped with one disconnecter, type EDT 4000, with visible double-break. Each compartment has an individual door, locked with a key. The door is equipped with an overview window for disconnecter contacts position observation.

Disconnectors are installed in the rear end of compartment; manual drive is in the front end. Front and rear parts of compartment are divided with a panel with overview window. Each disconnecter drive axis is controlled from its reducer.



SINGLE-LINE DIAGRAM RU-825RS

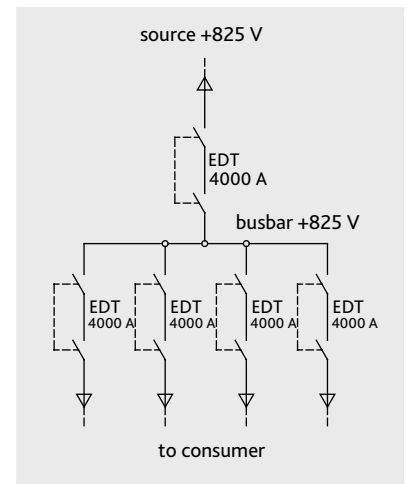

TECHNICAL DETAILS RU-825RS

Name of parameter	Unit	Value
Disconnecter type	-	EDT 4000
Rated voltage of power circuit	V	825
Rated current of power circuit	A	4000
Dynamic stability current	kA	100
Electric drive control voltage (DC)	V	220
Lighting circuit voltage (50 Hz)	V	220/12
RU-825RS casing protection class (except places of bus bars going out to contact rail)	-	IP54
Servicing	-	One-side
Mechanical stability, min	cycles	20000
Weight, max.	kg	600

OVERALL DIMENSIONS RU-825RS

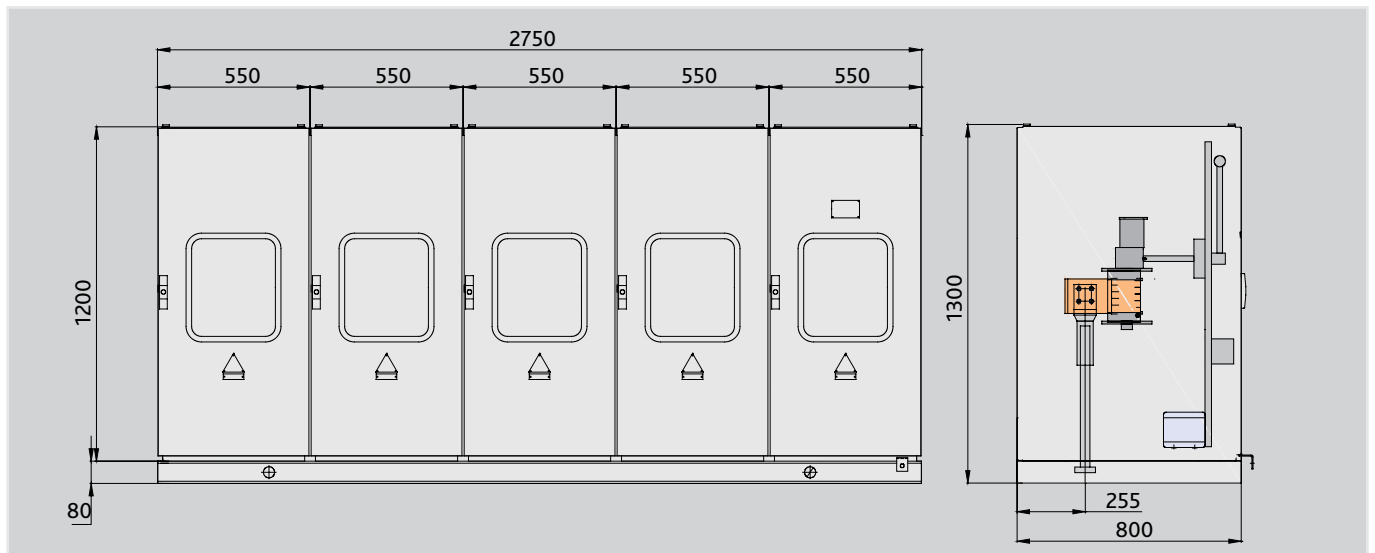

RU-825SR SWITCHGEAR (SECTIONING WITH DISCONNECTORS)

Sectioning switchgears with disconnectors RU-825SR are applied in traction network of metro depot as supply circuit 825 V switching devices.

They provide switching of supply line 825 V with rated current 4000 A.

RU-825SR is structurally made as one-side serviced metal cabinet, divided into two compartments: compartment of disconnector for circuit plus 825 V and compartment of disconnector for circuit minus 825 V. Each compartment is closed with a separate door, provided with a lock and overview window for disconnector position defining.

Reducer control lever is located behind the door of compartment of disconnector for circuit plus 825 V. Overview windows are also in side walls of compartments.

The cabinet is installed on foundation. Disconnectors drive axes are interlocked in one reducer, it provides possibility of disconnectors control from one manual drive.

TECHNICAL DETAILS RU-825SR

Name of parameter	Unit	Value
Disconnector type	-	EDT 4000
Rated voltage of power circuit	V	825
Rated current of power circuit	A	4000
Dynamic stability current	kA	100
Electric drive control voltage, DC	V	220
Lighting circuits voltage (50 Hz)	V	220/12
Protection class оболочки	-	IP54
Servicing	-	One-side
Mechanical stability, min	cycles	20000
Weight, max.	kg	350

SINGLE-LINE DIAGRAM RU-825SR

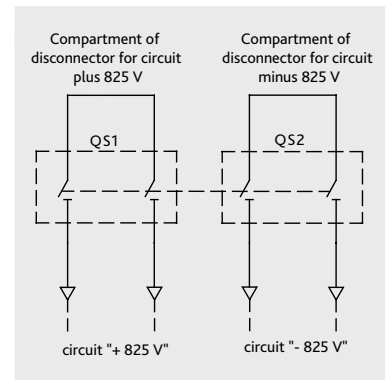

OVERALL DIMENSIONS RU-825SR

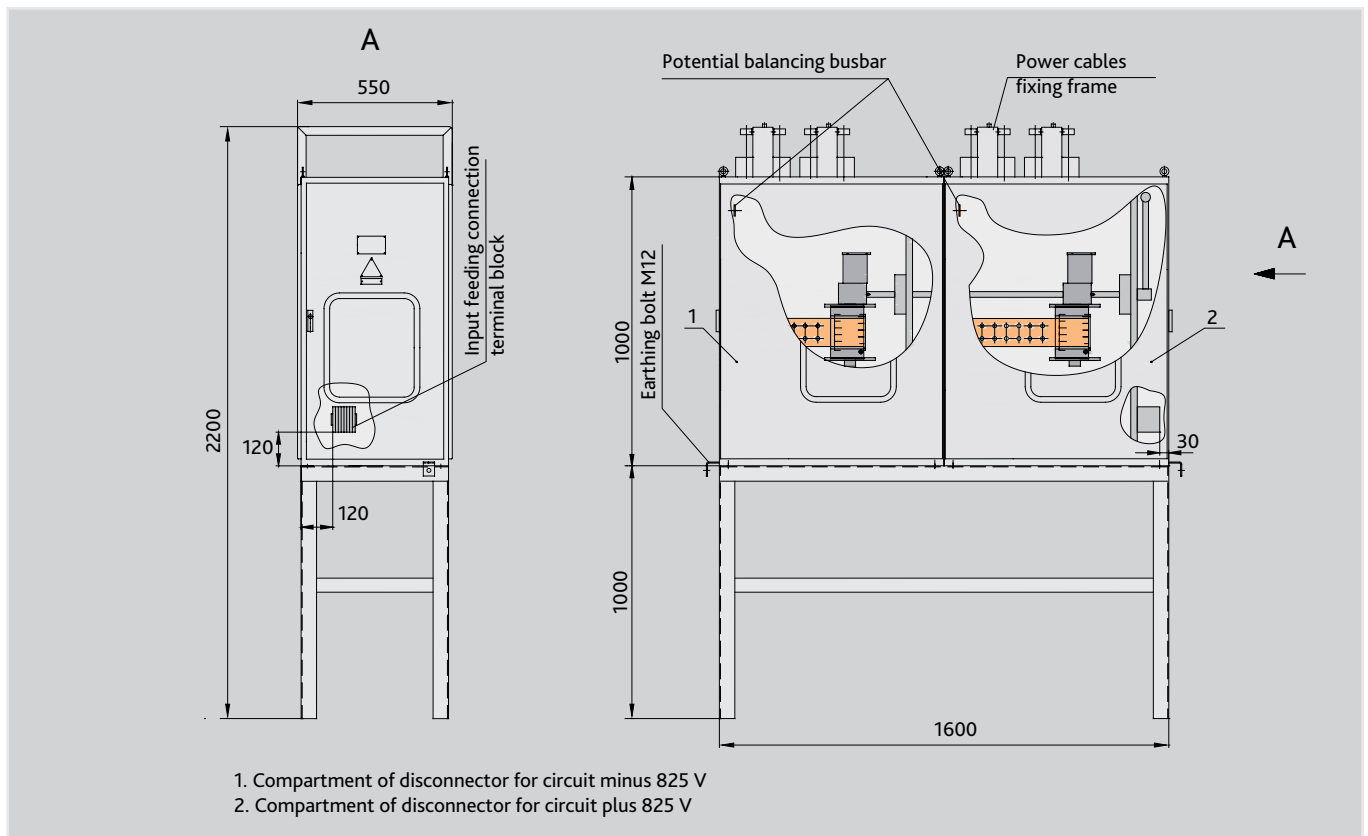

RU-825PP SWITCHGEAR (SWITCHING WITH DISCONNECTOR)



RU-825PP is designed for operation in metro depot traction network as contact rails feeding circuits switching device.

RU-825PP is structurally made in a form of metal two-sectional double-side serviced cabinet. One disconnector type EDT 4000 with visible double break is installed in the right section. Busbar for cables connection is in the left section. The cabinet has doors locked with the help of a key. The right section door is equipped with survey window for disconnector contacts position observation.

TECHNICAL DETAILS RU-825PP

Name of parameter	Unit	Value
Disconnector type	-	EDT 4000
Rated voltage of power circuit	V	825
Rated current of power circuit	A	4000
Lighting circuit rated supply voltage (50 Hz)	V	220/12
Protection class	-	IP 54
Cooling	-	natural air
Weight, max.	kg	400

The disconnector is installed in the rear of the cabinet; the manual drive is in front. The front and rear parts of cabinet are divided with a panel with survey window. Disconnector drive axis is controlled from reducer.

The cabinet is installed on the basis. 3 cables with section 625 mm² can be connected to disconnector input busbar. The cables are input in the cabinet from below through sealed lead-ins. Output busbar is led out from behind the cabinet for connection with contact rail.

DC double-pole disconnector, type EDT 4000 is a power switching device. The disconnector is used for connection and disconnection of plus 825 V circuits in metro depot traction network contact rails supply circuit.

Disconnector is controlled with reducer on the assumption of no-load. Reducer handle has fixed extreme positions. Disconnector closing (opening) is done by reducer handle switching to position «Disconnector On» («Disconnector Off»).

OVERALL DIMENSIONS RU-825PP

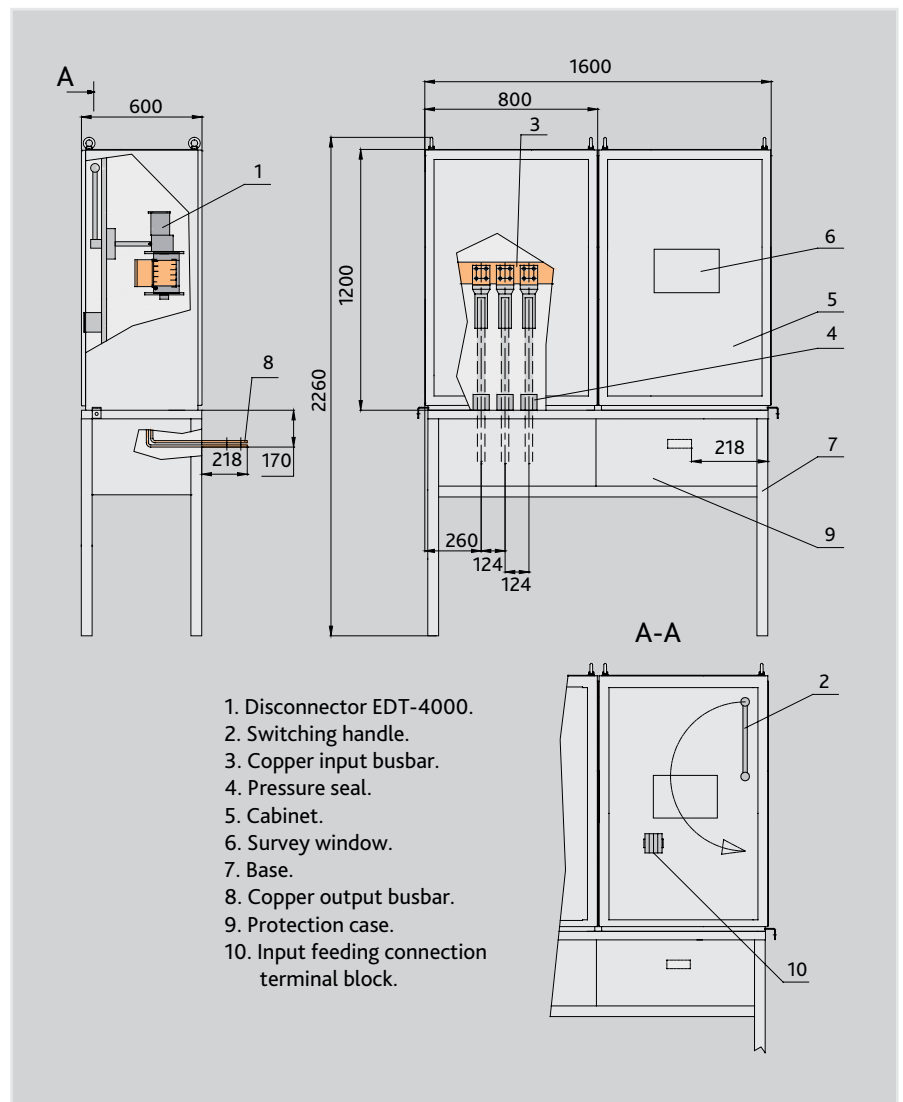

IMPLEMENTED PROJECTS



METRO

Almaty Metro

(Republic of Kazakhstan)

"Turn-key" supply of switchgears:

- RU-825LR - 50 units;
- RU-825PK - 119 units.

Baku Metro

(Republic of Azerbaijan)

"Turn-key" supply of switchgears:

- RU-825LR - 52 units;
- RU-825PK - 50 units.

Minsk Metro

(Republic of Belarus)

"Turn-key" supply of switchgears:

- RU-825LR - 81 units;
- RU-825PP - 34 units;
- RU-825ZK - 7 units;
- RU-825PR - 10 units.

Kiev Metro

(Ukraine)

"Turn-key" supply of switchgears:

- RU-825LR - 112 units;
- RU-825PK - 24 units;
- RU-825PR - 39 units;
- RU-825PP - 27 units;
- RU-825RS - 7 units.

Kharkov Metro

(Ukraine)

"Turn-key" supply of switchgears:

- RU-825LR - 15 units;
- RU-825PR - 1 units;
- RU-825PK - 40 units;
- RU-825PP - 20 units;
- RU-825RS - 1 unit.

Nizhny Novgorod Metro

(Russian Federation)

"Turn-key" supply of switchgears:

- RU-825LR - 16 units;
- RU-825PK - 15 units.

Yekaterinburg Metro

(Russian Federation)

"Turn-key" supply of switchgears:

- RU-825LR - 21 units;
- RU-825PK - 23 units.

Moscow Metro

(Russian Federation)

Supply of switchgears:

- RU-825LR - 10 units;
- RU-825PK - 17 units.

St. Petersburg Metro

(Russian Federation)

Supply of switchgears:

- RU-825LR - 4 units.

Private Joint Stock Company
PLUTON

5 Novostroyek St.
Zaporozhye 69076, Ukraine

Telephone/Fax:
+380 (61) 239-7900
+380 (61) 239-7901

E-mail: info@pluton.ua

www.pluton.ua

PrJSC PLUTON. All rights reserved