



CABLE CONTROL SYSTEM

CITY ELECTRIC TRANSPORT ■
RAILWAYS ■ METRO ■ INDUSTRY

CABLE CONTROL SYSTEM

Cable control system is an innovative system for power cables integrated monitoring based on PLUTON current developments.

Cable control system is provided for internal and external cable insulation resistance values measurement in traction networks up to 1000V DC.

The aim of system implementation is to prevent emergency situations in case of power cable insulation properties degradation.

Cable control system was designed as a component of traction network monitoring and protection system SMTN-3, but due to discrete signals for control and signaling cable

control system can be operated autonomously as an independent device.

PLUTON smart solutions used in cable control system, provide measurement in real time mode.

Data transfer between cable control system and SMTN-3 central unit is going via optical fiber. Moreover, optical fiber provides electrical isolation between systems modules and ensures safe usage of device.

The main function of cable control system module is to give signal in case of cable insulation properties degradation below the set threshold values.



▲ Cable control system module

Data exchange with SMTN-3 additionally provides complete control of the module state, measured values transfer, measured values control in long term dynamics, providing control of power cable insulation properties degradation for a long period of time, and allows to foresee critical decrease of cable insulation resistance.

Cable control system module is supplied completely from traction network, therefore, as a rule, the module is installed in switchgear busbar compartment and requires no additional external power sources, galvanic isolation of power circuits, thereby providing more effective safety.

The module housing is made of insulating material providing reliable insulation against electric shock. Housing material is halogen-free, does not support combustion, and corresponds V-0 classification of UL94 fire safety standard.

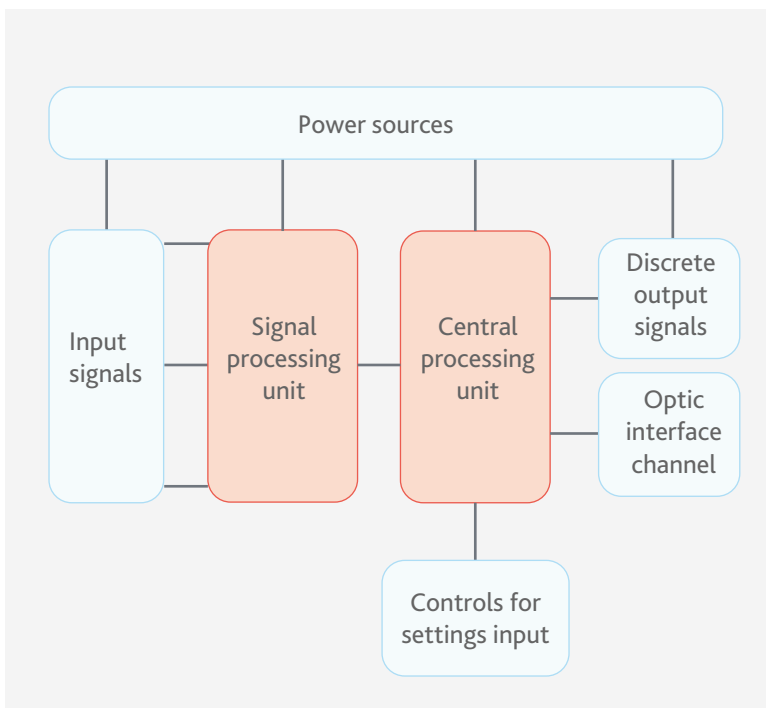

▲ Cable control system structure

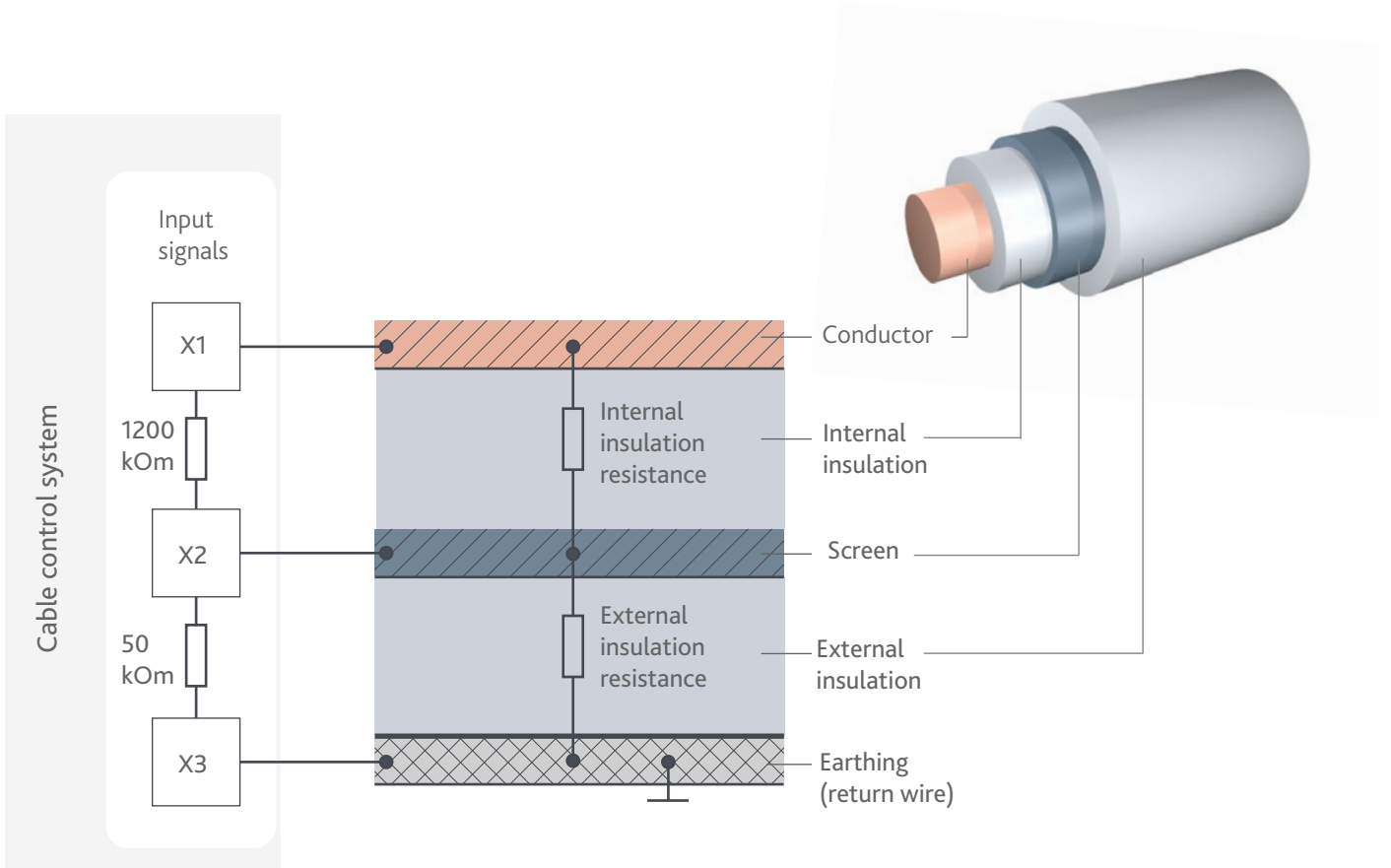

▲ Diagram of cable connection to cable control system module

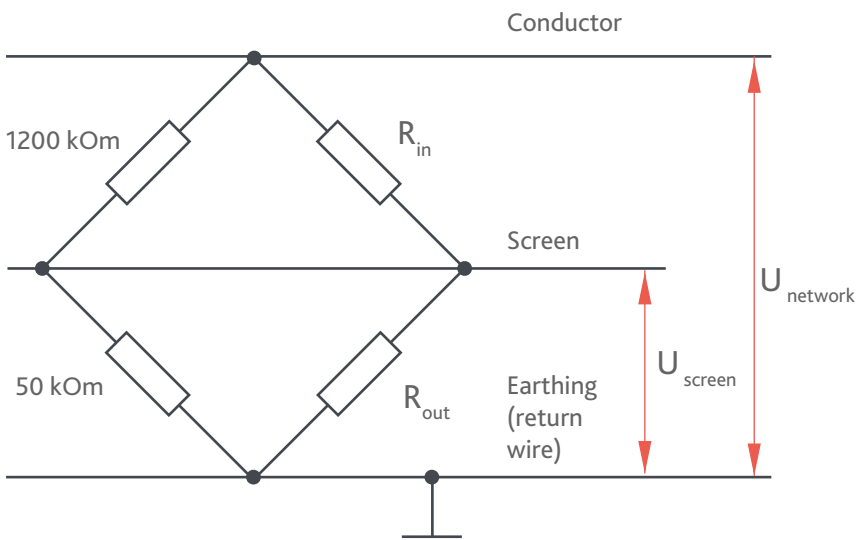

▲ Measuring circuit

Monitoring principle is based on cable screen voltage measuring relative to earthing, and comparing of this potential to a reference one. Reference voltage is set with resistances built in the module.

Cable internal and external insulation resistance is the branch of resistive bridge. The second branch consists of built-in resistors with known ratings.

Recalculation of voltage values on the bridge branches in resistances is made according to algorithms in the module. Insulation resistance degradation signal is given if calculated values become lower the settings.

MAIN TECHNICAL DATA

Main technical data of cable control system

Name of parameter	Value
Operational voltage	400-1000 V DC
Settings range for insulation external damage limit values	50 kOm – 500 kOm *
Settings range for insulation internal damage limit values	200 kOm – 2 MOm **
Device reaction rate for input parameters changing	max. 1 s

* Sampling (2, 4, 6, 8, 10, 12, 14, 16, 18, 20, 25, 30, 35, 40, 45, 50)* 10 kOm

** Sampling (2, 3, 4, 5, 6, 7, 8, 9, 10, 11, 12, 15, 17, 18, 20) * 100 kOm

Discrete outputs

NC/NO relay contacts act as output signals. Contacts parameters are given in the table. The module provides three pairs of contacts for the following alarms:

- voltage presence (under network voltage from +430 to +1000 V);
- external insulation damage;
- internal insulation damage;
- cable insulation calculated
- resistance decrease below the setting.

Main technical data of contacts

Name of parameter	Value
Number and type of contacts	2 C/O, 2 NO
Maximum voltage of contacts, V AC/DC	400 / 250
Minimum switching voltage, V	24
Rated load current: - AC - DC	10 A / 250 V 10 A / 24 V
Minimum switching current, mA	100
Maximum switching current, A	14
Contact current continuous-duty rating, A	10
Contact resistance, mOhm	<100
Breakdown voltage, V: - between coil and contacts - of contact gap - between conductor wires	5000 1000 4000

Interface output

Interface output is provided for serial, asynchronous data transmission via fiber optic cable to SMTN-3 central processing module. Fiber optic components are designed for 1 mm fiber optic cable with data transmission rate of minimum 40 kbaud.

Data transmission rate: 38400 Bit/s, 8 Bit, parity check 1 stop bit.

DIAGRAMS OF CONNECTIONS

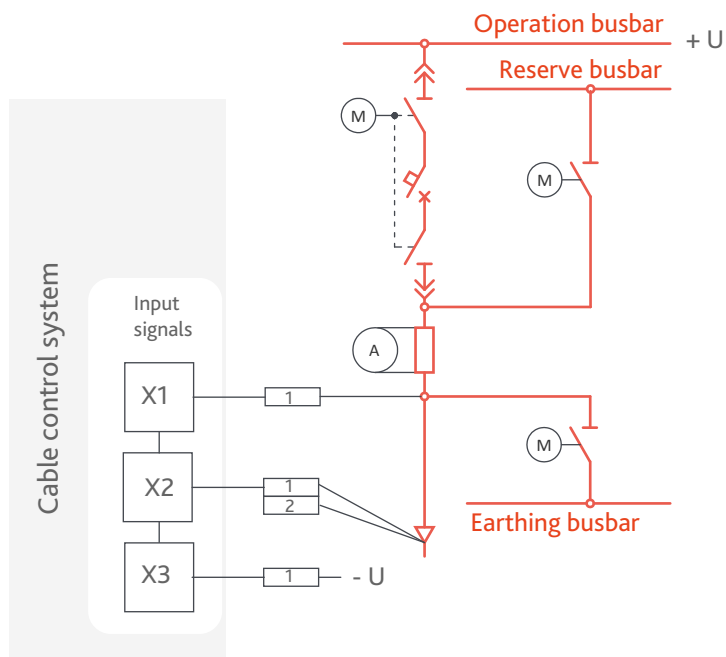

▲ Diagram of cable control system connection to switchgear

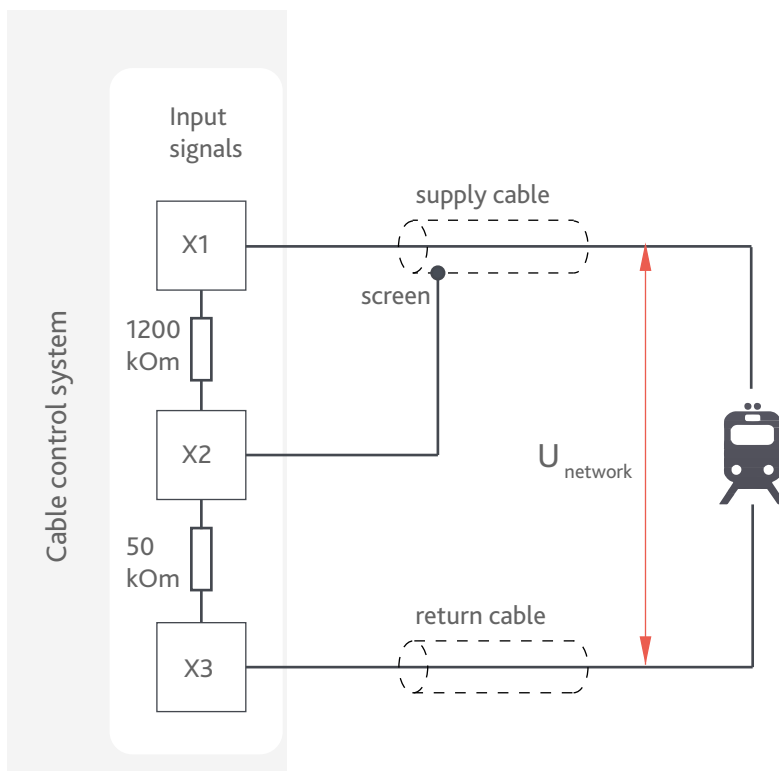

▲ Diagram of connection to cable control system module

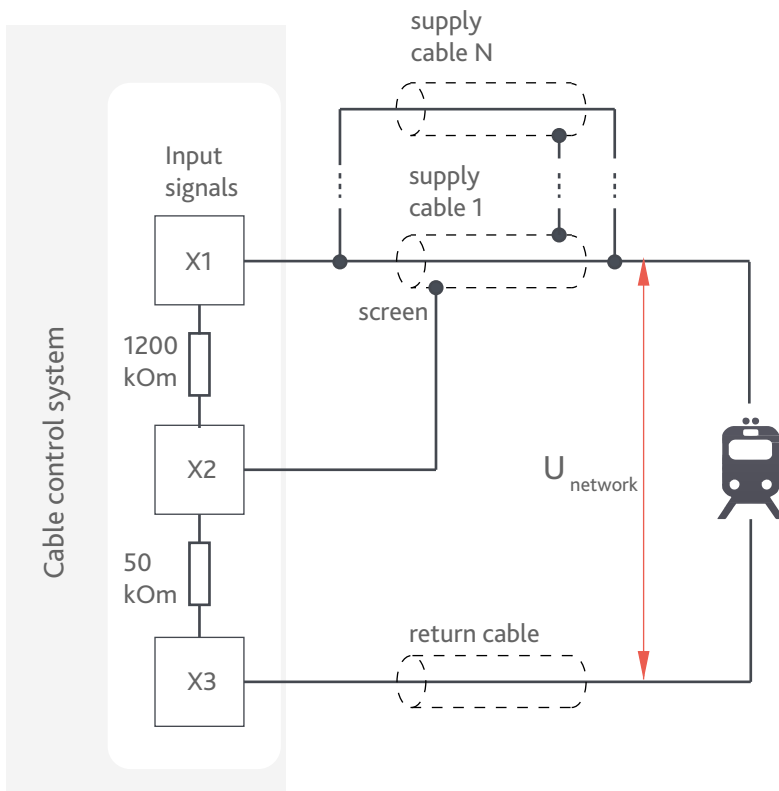
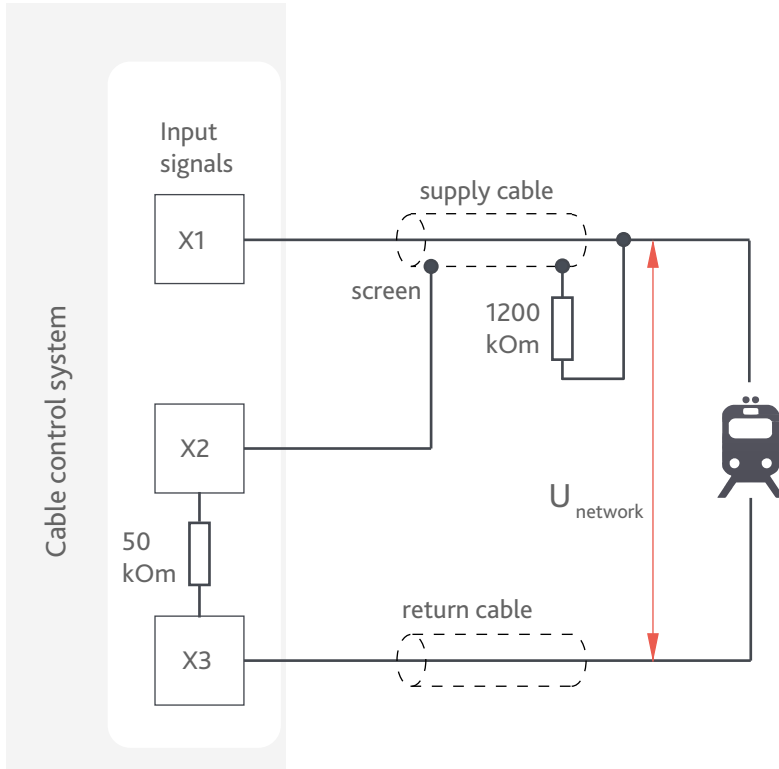

▲ Diagram of connection to cable control system module

E-mail: info@pluton.ua
www.pluton.ua

