



RECTIFIERS

CITY ELECTRIC TRANSPORT ■
RAILWAYS ■ METRO

ABOUT COMPANY

PLUTON is the modern innovative manufacturer of electrotechnical equipment for city electric transport, metro and railways. The Company holds key positions in electrical industry and has been successfully working over 30 years implementing the strategy of intensive growth, development and continuous improvement of products and services quality.

More than 70 types of PLUTON equipment are supplied to various countries of the world and successfully applied in the field of transport, power industry and production sector. PLUTON Group has representative offices in 8 countries and continues to develop dynamically and extend its global presence.

PLUTON confirmed compliance of its management principles with international standards of quality management system ISO 9001:2015, Environmental Safety ISO 14001:2015, as well as occupational safety and health ISO 45001:2018 requirements.

Due to our vast experience and innovative technologies, we provide secure, reliable and efficient power distribution. We are building the future, creating products of up-to-date level in compliance with the international standards that ensure safety and comfort of Customers.

We provide a full range of services: from design up to installation and commissioning of the supplied equipment on operation site. Furthermore, we provide the following services after equipment start-up:

- personnel correct and safe operation and maintenance training;
- warranty and post-warranty maintenance;
- spare parts supply.

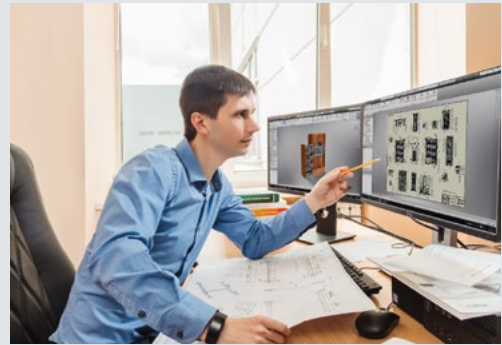

RECTIFIERS FOR TRACTION SUBSTATIONS

Due to many years of experience in electrotechnical field, PLUTON offers a wide range of modern rectifiers with application of the latest technological global achievements. This applies the cabinet design solutions, rectifier power part, software, rectifier protection, diagnostics and control systems, diagnostics of converter transformer, electrical installation, maintenance and repair technologies.

Rectifiers are provided for operation in the power supply systems of metro, city electric transport (tram, trolleybus, monorail) and railways rolling stock.

Over a 30-year period PLUTON gained the vast experience in design, manufacturing and startup of rectifiers. Our solutions are successfully used in transport systems of Ukraine, Sweden, Romania, Republic of Poland, Republic of Turkey, Republic of Kazakhstan, Republic of Uzbekistan, Latvia, Republic of Azerbaijan, Moldova and other countries.



/ more than 500 rectifiers manufactured by PLUTON are implemented at traction substations all over the world.

	600 V	750 V	825 V	1500 V	1650 V	3000 V	3300 V
Tram	■	■	■	■			
Trolleybus	■	■					
Light rail	■	■	■	■			
Metro		■	■	■			
Railways				■	■	■	■

BENEFITS

Customization

- / fixed and withdrawable design;
- / 12-pulse, 6-pulse “bridge” and six-phase “zero” rectification circuits;
- / “diode-diode” or “diode-fuse” rectifier power part (with Np+1 protection class according to EN 50328 standard);
- / connection of AC power supply in the upper or the lower rectifier side;
- / application for all types of traction networks with the following typical output voltages:
600, 750, 825, 1500, 1650, 3000, 3300 V
and rectified currents:
800, 1000, 1250, 1600, 2000, 2500,
3000, 3150, 4000, 5000, 7000, 8000 A.

Compliance with international standards

PLUTON routinely proves the compliance of its rectifiers with the requirements of IEC 60146-1-1:2009-06, EN 50328:2003 international standards with type-testing for compliance with the specified standards in test center IPH Institut (Berlin, the Federal Republic of Germany).



Reliability and safety

- / innovative schematic and technical solutions;
- / microprocessor protection, diagnostics and control system;
- / continuous monitoring of power semiconductor devices parameters;
- / temperature monitoring and reverse voltage distribution on each diodes pair;
- / high overload capacity;
- / effective multilevel protection system against internal switching and external overvoltages;
- / rectifiers are manufactured for various failure modes (T, F, R modes) of semiconductor devices according to EN 50328.

Maintainability

- / the lowest maintenance;
- / easy access to the circuit components for simplification of technical maintenance;
- / application of maintenance-free contact joints technology in the power part of rectifiers;
- / controlled diodes pressure load due to application of calibrated crimping components for “diode-cooler” assembly.

Cost saving

- / long lifetime and a high level of technical and performance characteristics due to application of modern high-quality, reliable and safe components;
- / space-saving overall dimensions.

RECTIFIERS COMPLETENESS

We produce fixed and withdrawable rectifiers.

Commonly, rectifiers are equipped with modern dry transformers with RESIBLOC® windings (or similar), with a capacity from 630 kVA, with various combinations of high

(HV) and low (LV) winding voltages. Further, rectifiers can be equipped with transformers with windings, made according to the cast technology, with epoxy resin filler reinforced with fiberglass.



RESIBLOC® transformers

RESIBLOC® converter transformers are successfully applied for the transport systems in many countries of the world.

Rectifier with RESIBLOC® windings has the following benefits:

- fire safety;
- environmental compatibility;
- “cold” start with maximum load;
- high resistance to dynamic loads under overloads and short circuits;
- overvoltage;
- minimum maintenance;
- reliable operation under conditions of high pollution, high humidity, low temperatures.

Transformers have original design of HV and LV windings, made of wire and foil. Windings are shrouded with epoxy-impregnated fiberglass string.

High content of fiberglass (approximately 80 %), and combination of lateral and longitudinal reinforcement makes winding with a very high lateral and longitudinal strength. Transformer windings mechanical strength is 650–750 N/mm².

Transformers can operate under conditions of 100 % humidity, water vapor condensation, as well as chemical pollution. Transformers can be equipped with low noise radial fans. Forced cooling system allows increasing transformer’s rated capacity up to 40 %.

FIXED RECTIFIERS

Main technical parameters of fixed rectifiers

Name of parameter	Unit	Value			
Structure of rectifier power part	-	"diode-fuse"	"diode-diode"		
Rated voltage	V	600, 750, 825	600, 750, 825	1500, 1650	3000, 3300
Rated current	A	4000...8000*	800...4000*	2000...4000*	2000...4000*
Auxiliaries network voltage	V	=110/220; ~230			
Rectification circuit	-	bridge (6-pulse, 12-pulse)			
Diagram of power part	-	fig. 19 (p. 25)	fig. 14 (p. 22) fig. 15, 16 (p. 23)	fig. 17 (p. 24)	fig. 18 (p. 24)
Number of connection circuit (acc. to EN 50328)	-	8, 9, 12			
Rectifier cooling type (acc. to EN 50328)	-	natural (AN), forced (AF)			
Duty class (acc. to EN 50328)	-	VI*			
Overvoltages	-	1.0 — continuous 1.5 — 7200 s 3.0 — 60 s			
Failure mode of semiconductor devices (acc. to EN 50328)	-	T, F, R modes			
Maximum ambient temperature	°C	40*			
Altitude	m	1000			
IP class (acc. to IEC 60529)	-	IP20, IP21	IP21	IP21	IP20, IP21, IP43

* other values — upon request

Rectifiers are manufactured for both indoor and outdoor installation. In case of outdoor installation, control and diagnostics system is located separately and installed indoors or in a cabinet with regulated environment.

Rectifiers can be manufactured with air natural (AN) and air forced (AF) cooling (according to EN 50328). Air forced cooling is actually combined natural air and forced air cooling. The rectifier operates with natural cooling under loads lower or close to the rated ones. In case of risk of overheating under overloads, fans are switched on and forced cool diodes. Fans switch off automatically after overload disappearance and diodes temperature drop.



COMPONENTS

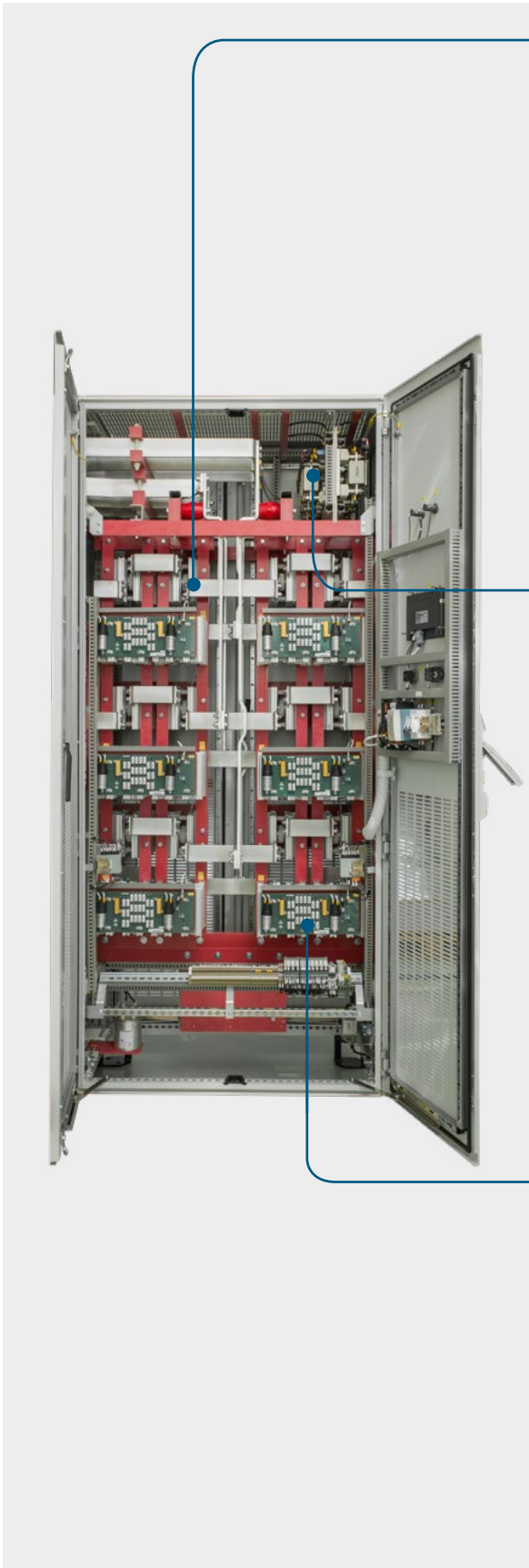

Power diodes



Pill power diodes manufactured by VISHAY are applied. Two diodes in series are installed in each arm of “diode-diode” rectifier.

Switching surge protection



Protection of power semiconductor devices (diodes) against internal and external switching surges is implemented in rectifiers. Each diode is protected against internal switching surges with RC circuit, installed on the galvanic insulation board, and against external switching surges combined with RC circuits and variable resistor with fuses, installed on the switching surges protection panels.

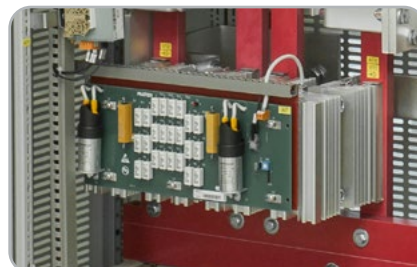

Galvanic insulation boards generate and provide information for analysis of the power diodes state diagnostics system with controller.

WITHDRAWABLE RECTIFIERS

Withdrawable rectifiers are produced with “bridge” 6- and 12-pulse rectification circuits (connection circuits 8, 9, 12 according to EN 50328). Rectifier arm can be made with “diode-diode” or “diode-fuse” structure. Power pill diodes, 25th grade, are applied for currents up to 3000 A. Power high speed fuse is applied in series with each diode in “diode-fuse” circuit.

Withdrawable rectifiers consist of fixed cabinet and withdrawable power unit, connected with the contacts system. Power unit can have three specific positions against fixed cabinet:

- operating position — power unit is completely rolled in, power contacts are closed with outgoing busbars;
- test position — power unit is rolled out 100 mm from the rectifier cabinet, where power contacts are taken 100 mm aside the outgoing busbars;
- servicing position — power unit is completely rolled out of the rectifier cabinet on the substation floor.

Maintainability

- / service position provides maximum ease of access to the components and power unit structural components, as well as to the rectifier busbar compartment;
- / power unit moving between operation and test positions is mechanized due to electromechanical drive and doesn't require any manual efforts of the staff;
- / power unit test position is an additional visual indicator of the device off-state (dismounted circuit).



Main technical parameters of withdrawable rectifiers

Name of parameter	Unit	Value	
Structure of rectifier power part	-	“diode-fuse”	“diode-diode”
Rated output voltage	V	600, 750, 825	
Rated output current	A	3000 - 8000	1200 - 4000
Duty class (acc. to EN 50328)	-	VI	
Overloads	s	1.0 — continuous 1.5 — 7200 s 3.0 — 60 s	
Auxiliaries network voltage	V	=110/220; ~230	
Rectification circuit	-	bridge, 6-,12-pulse	
Diagram of power part	-	fig. 22 - 23 (p. 27-28)	fig. 20, 21 (p. 26)
Number of connection circuit acc. to EN 50328)	-	8, 9	
Failure mode of semiconductor devices (acc. to EN 50328)	-	T, F, R modes	
Rated network frequency	Hz	50	
Cooling type (acc. to EN 50328)	-	natural, air (AN)	
Power factor (calculated), min.	-	0.95	
Efficiency factor (calculated), min.	%	98	
IP class (acc. to IEC 60529)	-	IP20	

WITHDRAWABLE RECTIFIERS

Protections

Overvoltage protection:

- protection of power semiconductor devices (diodes) against internal and external switching overvoltages is implemented in withdrawable “diode-diode” rectifiers. Each diode is protected against internal switching surges with RC circuit, and against external switching surges combined with RC circuits and variable resistor with fuses, installed on the switching surges protection panels;
- a damping capacitor is installed in parallel to each power diode for surge protection in “diode-fuse” rectifier. Rectifier is equipped (on DC side) with RC filter for protection against overvoltages from the side of traction network, and with panel with variable resistors with fuses.



Short circuit protection:

- rectifier is designed to withstand external short circuit without damages up to MV circuit breaker tripping;
- in “diode-diode” rectifier reach-through breakdown is excluded due to installation of two diodes in series into arms;
- in “diode-fuse” rectifier protection against internal short circuits is carried out due to power fuses, installed in series with each diode;
- rectifiers are produced for various semiconductor devices failure modes (T, F and R modes) according to EN 50328.

Serviceability and handling safety

Immediate accidental contact of personnel with live parts of busbar compartment is mechanically impossible due to protection panel.



Installation into DC-board

Withdrawable rectifiers are installed in the DC board with DC switchgears. It is the most effective approach to architecture of modular substations that provides:

- / compact arrangement of DC traction equipment set;
- / extra space inside the modular substation due to comprehensive single sided maintenance;
- / optimized costs for materials and installation works due to minimum space between rectifier and DC switchgears;
- / fast operation, as well as easy diagnostics and maintenance due to modular approach and interchangeability of withdrawable components of DC switchgears and rectifier.

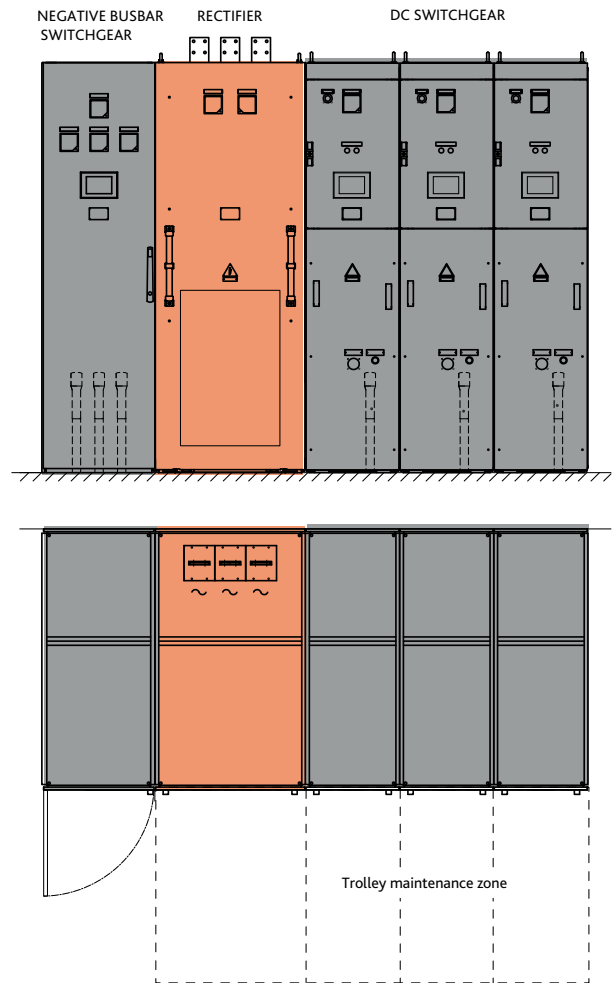

RECTIFIER CONTROL AND DIAGNOSTICS SYSTEM

Withdrawable and fixed rectifiers are equipped with microprocessor control and diagnostics system with displaying information about state of each diode on the visualization panel according to the following criteria: "normal operation", "parameters derating" (for "diode-diode" design), "breakdown", as well as about the diode temperature. Control system is carried out on the basis of SOTA controller, that meets IEC 61131 series of standards for PLC, and provides support of IEC 61850 protocol.

Monitoring of each diode parameters is carried out continuously during operation of the rectifier. Diagnostics according to the specified criteria allows significantly increasing failure-free operation of the rectifier.

In case of diode parameters changing to critical for this circuit level, the power diode should be replaced without its breakdown. In case of one diode breakdown, the "diode-diode" rectifier continues its operation without power loss till replacement of the broken diode.

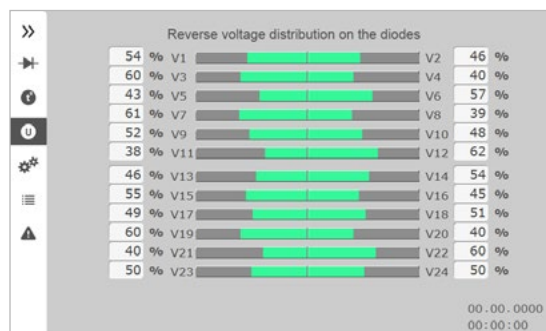
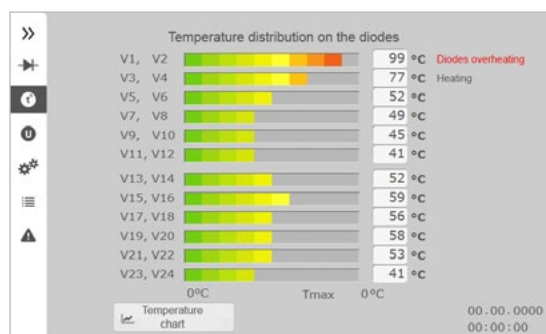
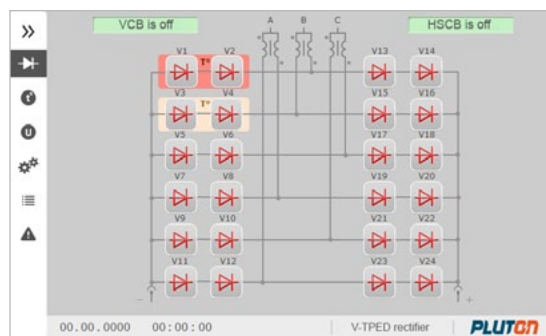

SOTA IEC 61131
IEC 61850

Information about state of the rectifier and its components is displayed on visualization panel, mobile devices (smartphone, tablet) or on the computer display via Web interface or special software.

Mnemonic symbols of rectifier diodes, graphs of reverse voltage distribution between diodes and arms temperature is displayed.

The communication with the MV switchgears protection devices and the upper level SCADA system is implemented in the rectifier.

Functions of rectifier control and diagnostics system

	diode-fuse	diode-diode
Monitoring:		
diodes state ("normal operation", "parameters derating", "breakdown")		■
temperature on each pair of diodes, 2 stages		■
transformer heating by 2 stages (peak heating and overheating)	■	■
fuses actuation:		
- at input protection panels	■	■
- at power diodes	■	
- at output protection panels	■	
temperature inside the cabinet (upon request)	■	■
doors state (for fixed rectifiers)		■
power unit position (for withdrawable rectifiers)	■	■
Visualization:		
position of rectifier (on/off-position)	■	■
single-line rectifier diagram	■	■
high voltage and high speed circuit breaker status	■	■
rectified current and voltage values	■	■
diodes state	■	■
actual temperature values of all pairs of diodes		■
temperature curve of maximum heated pair (trend)		■
reverse voltage distribution values on all diodes pairs		■
Control:		
power unit rolling in/rolling out (for withdrawable rectifiers)	■	■
Additional functions:		
displaying of warning and alarm messages	■	■
event logging	■	■
communication with the upper level (SCADA system)	■	■
support of IEC 61131, IEC 61850 protocols	■	■

OVERALL DIMENSIONS.

Fixed rectifiers

Rated output voltage, V	Rated output current, A	Rectification circuit acc. to EN 50328	Rectifier cooling type	W (Width), mm*	H (Height), mm*	D (Depth), mm*	Dimensional drawing
600	1000 - 2000	-	natural	600	2200	600	fig. 1 (p. 15)
600, 750, 825	800 - 2000	8	natural	1000	2200	600	fig. 2 (p. 15)
		9	natural	1200			
	2500	8, 9	natural	2000	2200	600	fig. 3 (p. 15)
	4000	8, 9	natural	4800	2200	600	fig. 4 (p. 16)
			forced**	2400	2200	600	fig. 3 (p. 15)
5000 - 8000	8, 9	forced**	4800	2200	600	fig. 4 (p. 16)	
1500, 1650	2000	8	natural	1400	2200	800	fig. 5 (p. 16)
	3150	8, 9	natural	4800	2200	800	fig. 7 (p. 17)
			forced**	2400			fig. 6 (p. 17)
	4000	8, 9	natural	4800	2200	800	fig. 7 (p. 17)
			forced**	2400			fig. 6 (p. 17)
2000	12	natural	2400	2200	800	fig. 6 (p. 17)	
3000, 3300	3150	12	natural	4800	2200	800	fig. 7 (p. 17)
			forced**	2400			fig. 6 (p. 17)
	4000	12	natural	4800	2200	800	fig. 7 (p. 17)
			forced**	2400			fig. 6 (p. 17)

* frame

** base 200 mm — for rectifiers with forced cooling type

OVERALL DIMENSIONS.

Fixed rectifiers

1	600 V	1000 - 2000 A	natural cooling	VI duty class
----------	-------	---------------	-----------------	---------------

2	600 V 750 V 825 V	800 - 2000 A	natural cooling	VI duty class
----------	-------------------------	--------------	-----------------	---------------

zero rectification circuit

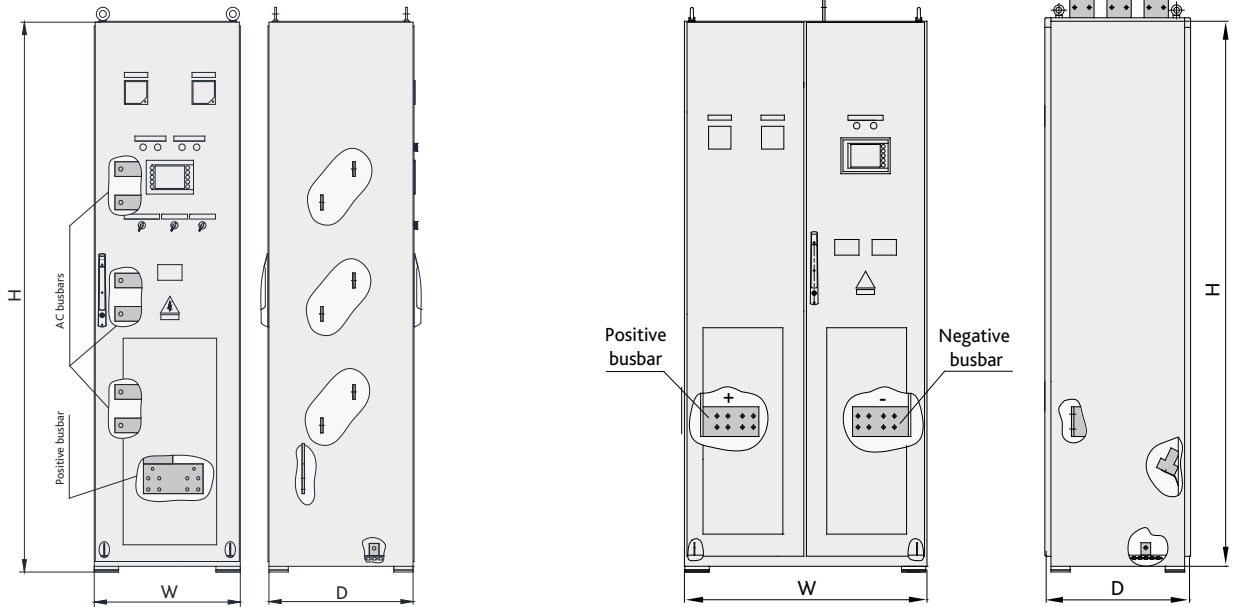

3	600 V	2500 A	natural cooling	VI duty class
	750 V	4000 A	forced cooling	VI duty class

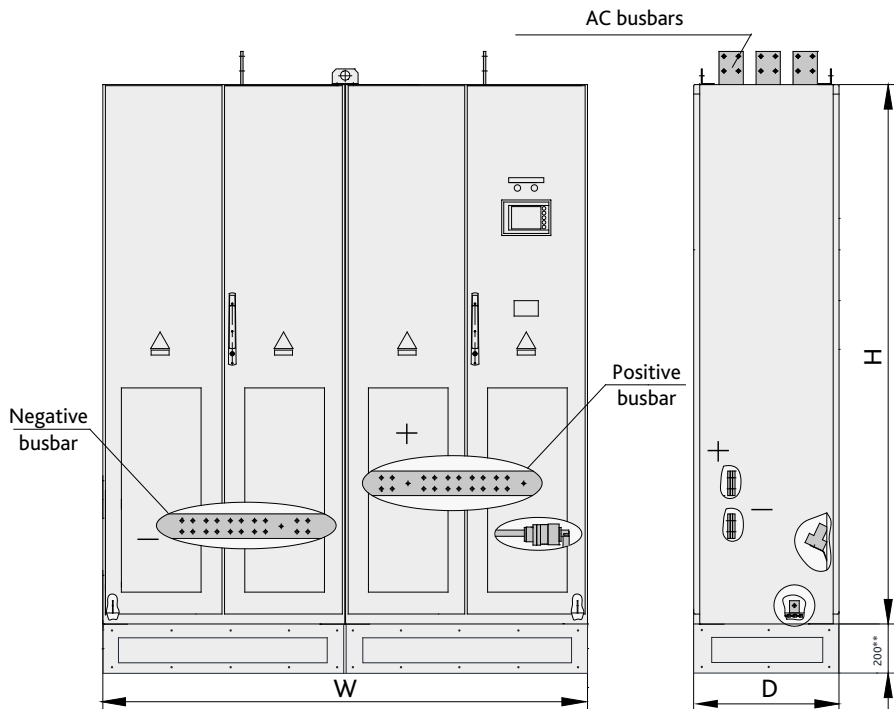

OVERALL DIMENSIONS.

Fixed rectifiers

4

600 V	4000 A	natural cooling	VI duty class
750 V	5000 - 8000 A	forced cooling	
825 V			

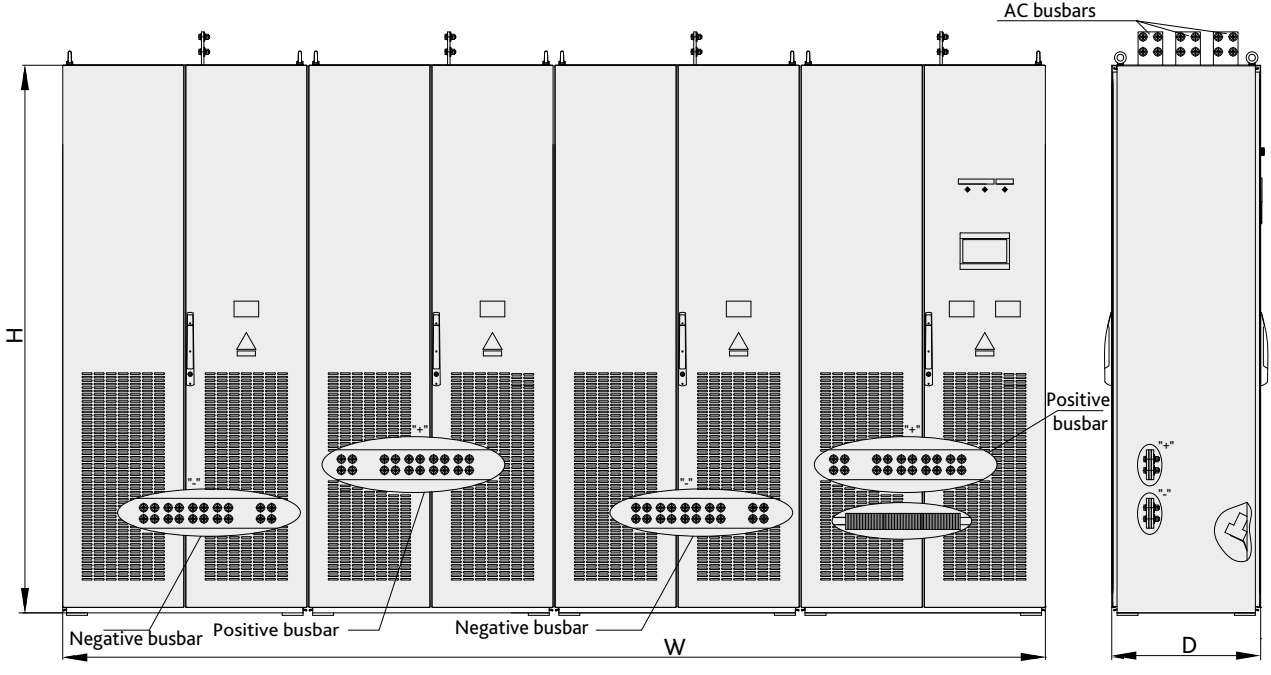

5

1500V	2000 A	natural cooling	VI duty class
1650V			

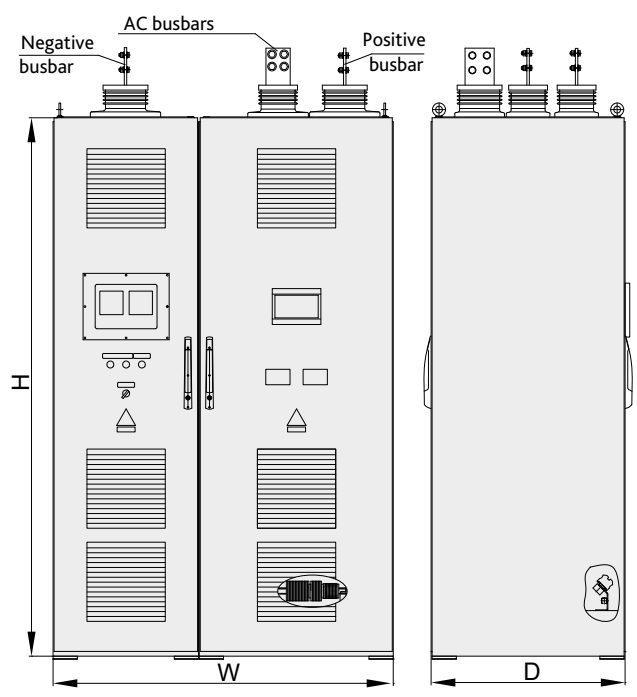

OVERALL DIMENSIONS.

Fixed rectifiers

6

1500 V	3150 A	forced cooling	VI duty class
1650 V	4000 A		
3000 V	2000 A	natural cooling	
3300 V	3150 A	forced cooling	
	4000 A		

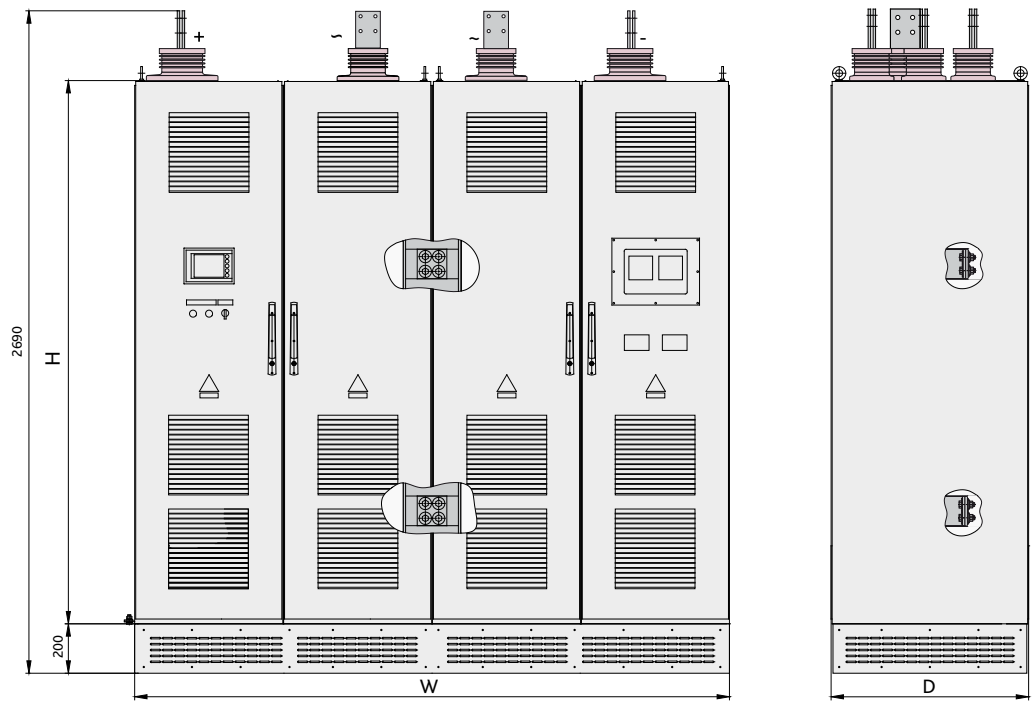

7

1500 V	3150 A	natural cooling	VI duty class
1650 V	4000 A		
3000 V	3150 A		
3300 V	4000 A		

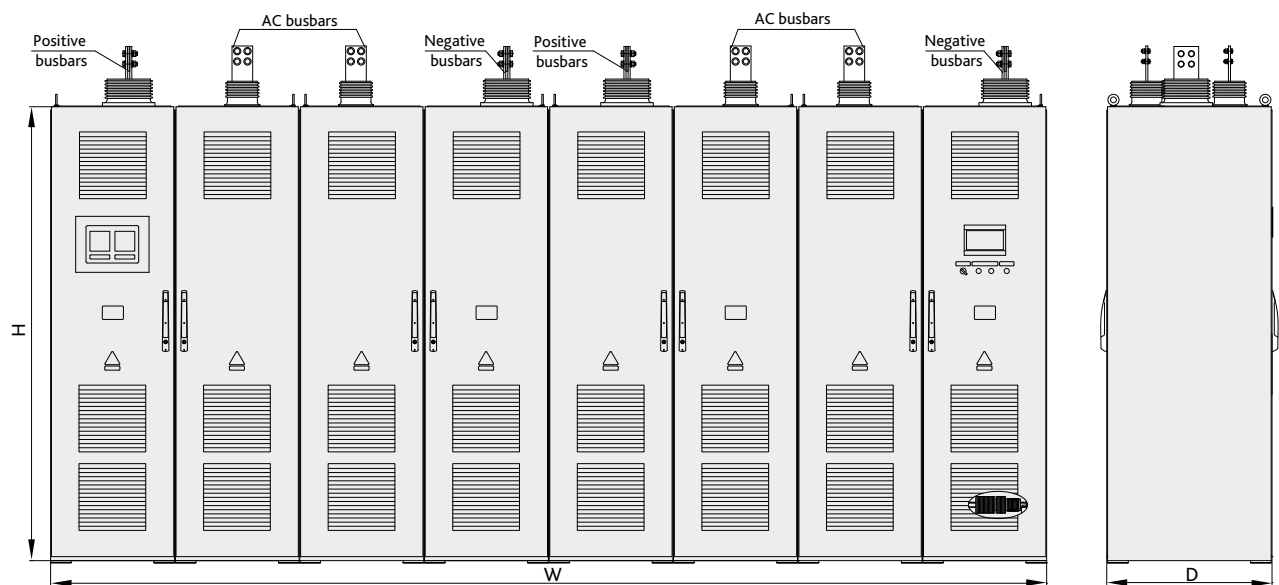

OVERALL DIMENSIONS.

Fixed rectifiers (outdoor installation)

3300 V	2000 A	natural cooling	VI duty class	outdoor installation	bridge rectification circuit
	3150 A	forced cooling	VI duty class	outdoor installation	

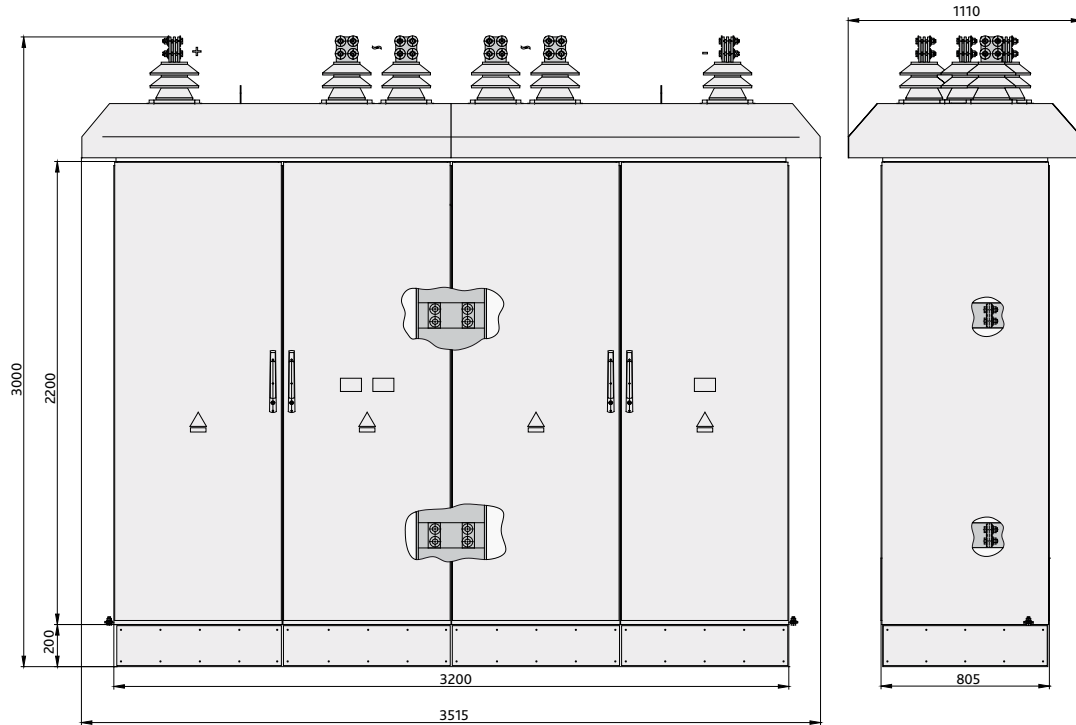

3300 V	3150 A	forced cooling	VI duty class	outdoor installation	zero rectification circuit

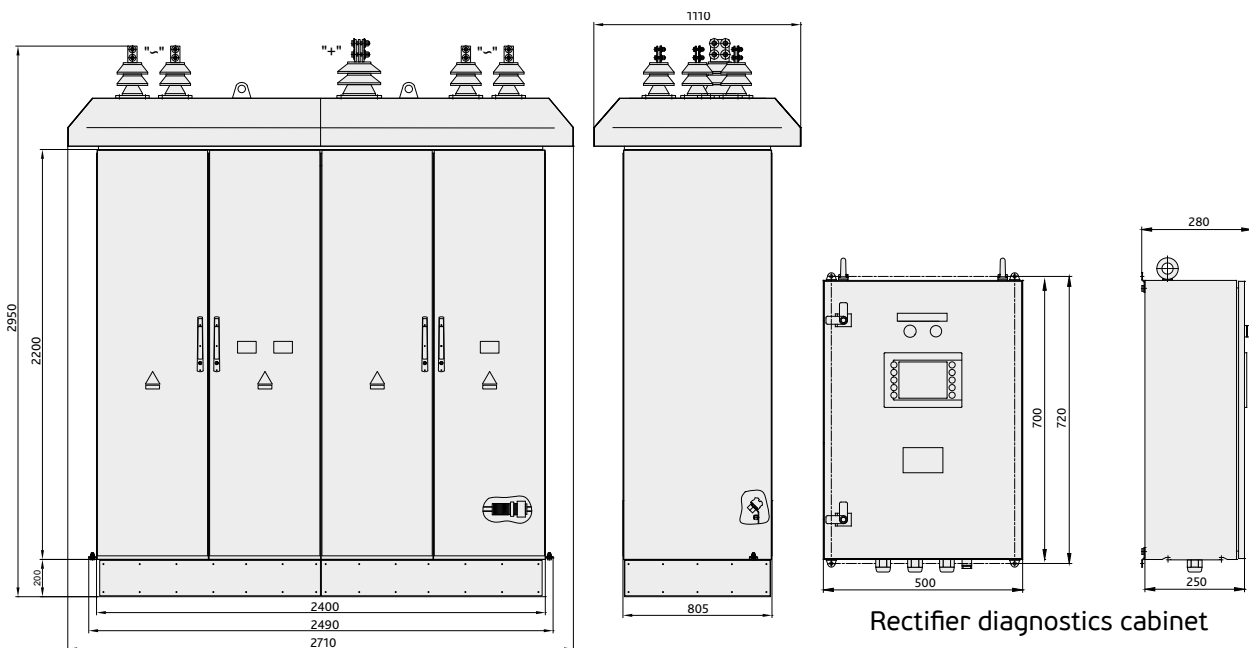

OVERALL DIMENSIONS.

Withdrawable rectifiers

Rated output voltage, V	Rated output current, A	Rectification circuit acc. to EN 50328	Rectifier cooling type	W (Width), mm*	H (Height), mm*	D (Depth), mm*	Dimensional drawing
600, 750, 825	1200 - 2000	8, 9	natural	600	2200	1400	fig. 10 (p. 19)
	2500-4000	8, 9	natural	1200	2200	1400	fig. 11 (p. 20)
	3000 - 4000	8, 9	natural	800	2200	1500	fig. 12 (p. 20)
	6000 - 8000	8, 9	natural	1600	2200	1500	fig. 13 (p. 21)

10

600 V 750 V 825 V	1200 - 2000 A	natural cooling	VI duty class	"diode-diode"
-------------------------	------------------	-----------------	---------------	---------------

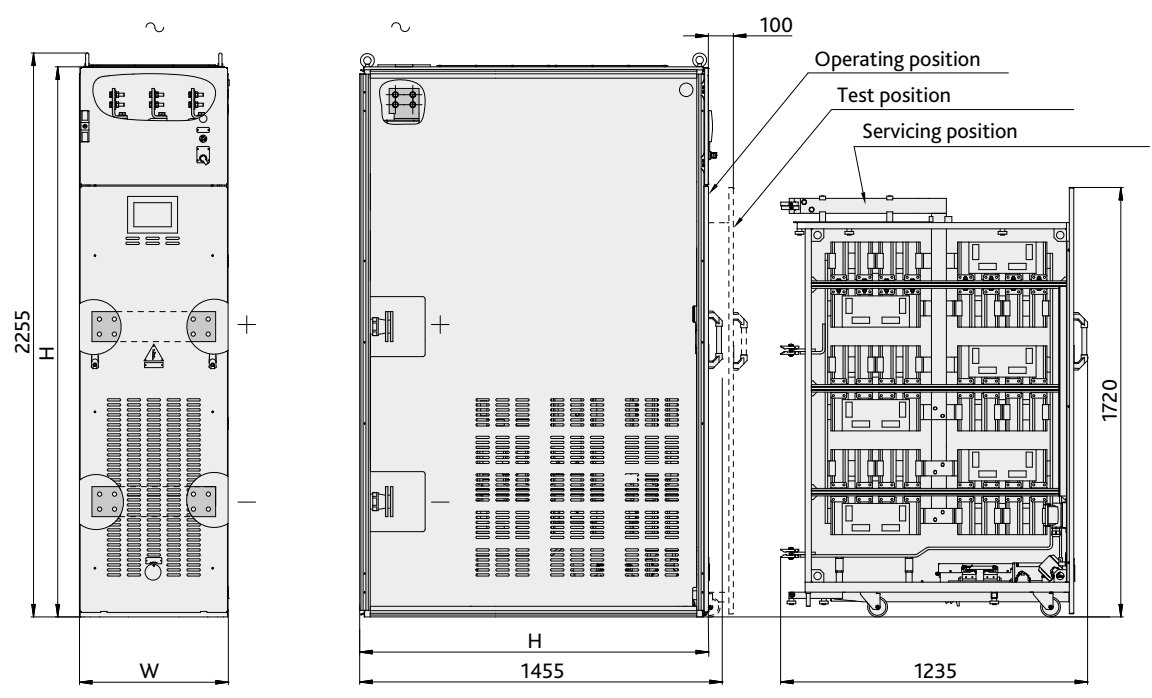

OVERALL DIMENSIONS.

Withdrawable rectifiers

11

600 V 2500 -
 750 V 4000 A natural cooling VI duty class "diode-diode"

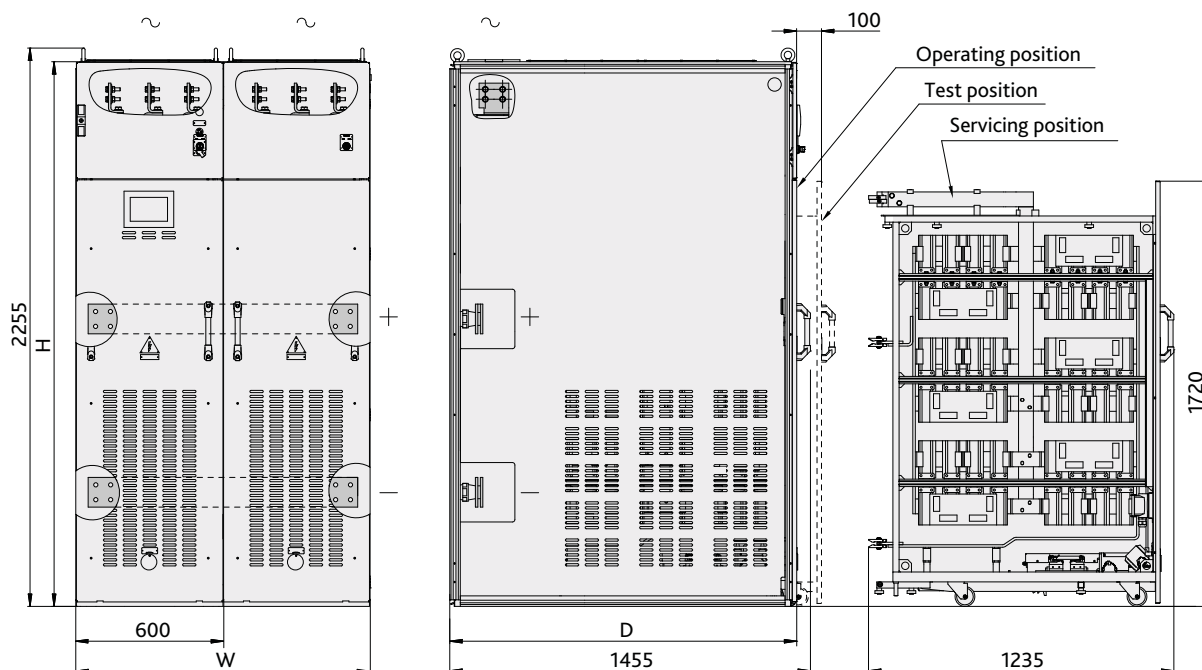

12

600 V 3000-
 750 V 4000 A natural cooling VI duty class "diode-fuse"

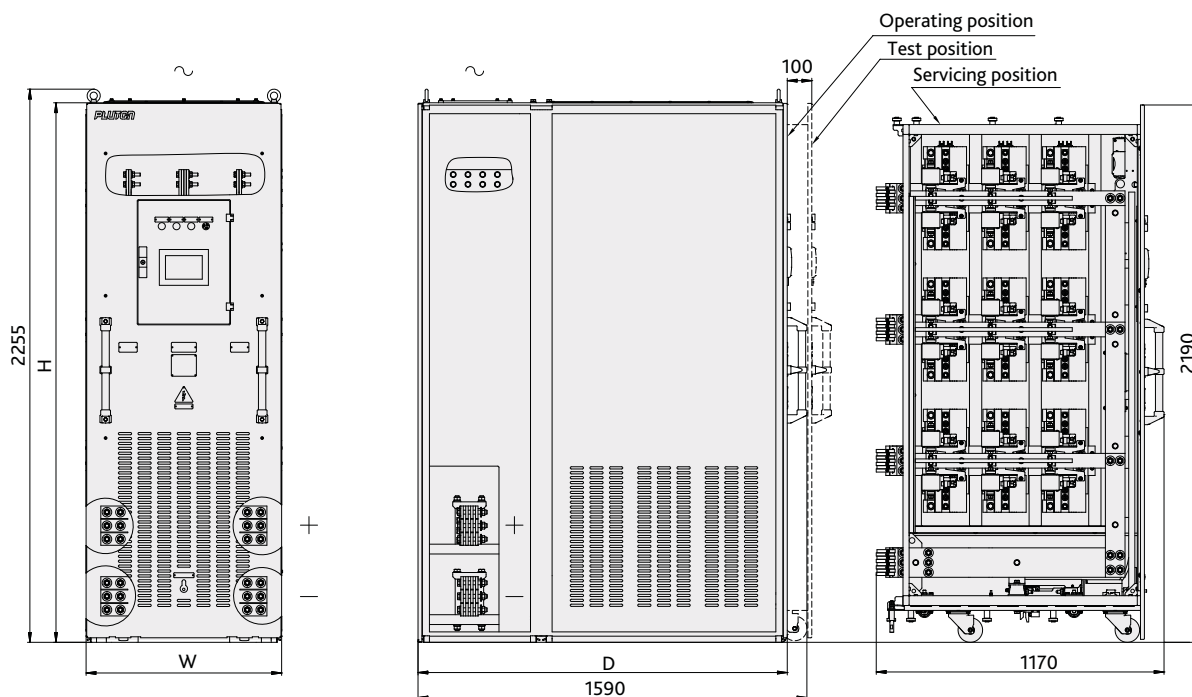

OVERALL DIMENSIONS.

Withdrawable rectifiers

13

600 V
750 V
825 V

6000 -
8000 A

natural cooling

VI duty class

"diode-fuse"

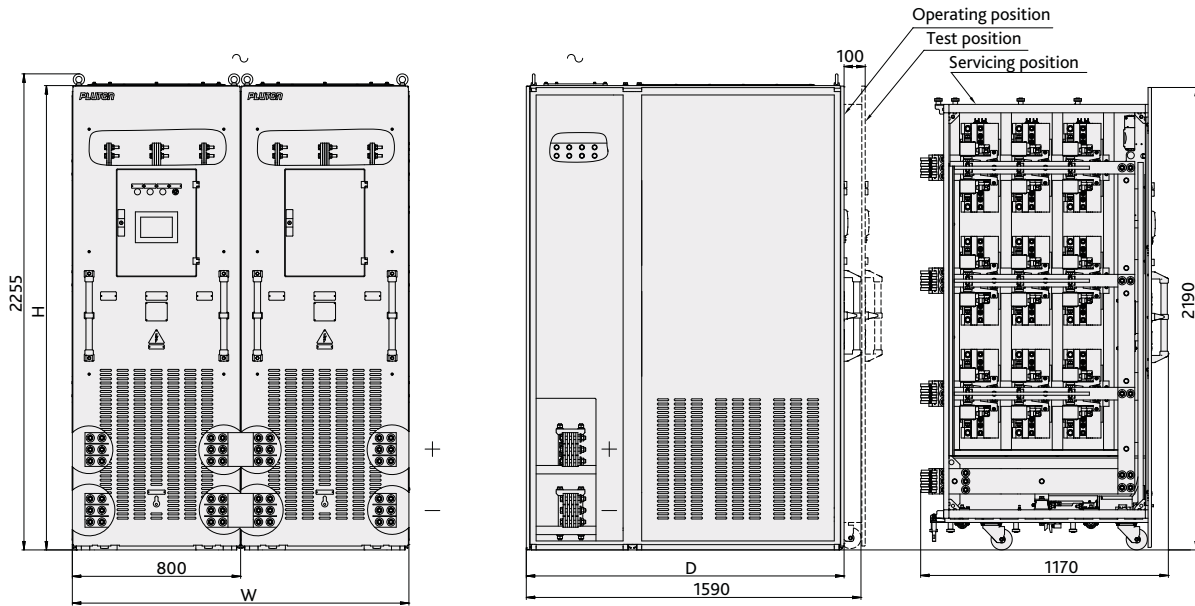

DIAGRAMS OF POWER PART.

Fixed rectifiers ("diode-diode")

14

600 V 1000 - 2000 A 6-pulse rectification circuit

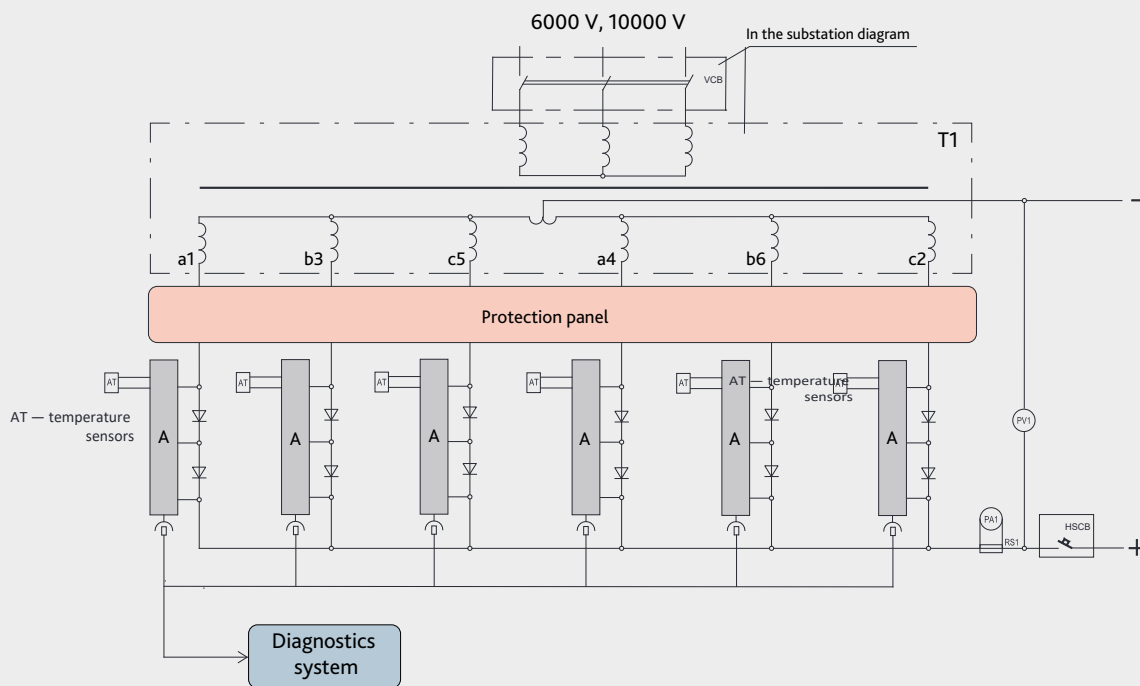

VCB — vacuum circuit breaker
HSCB — high speed circuit breaker

Protection panel

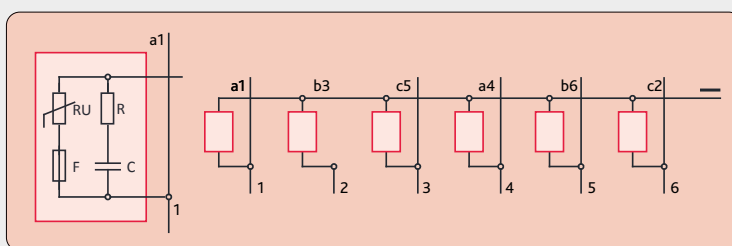

A — galvanic insulation panel

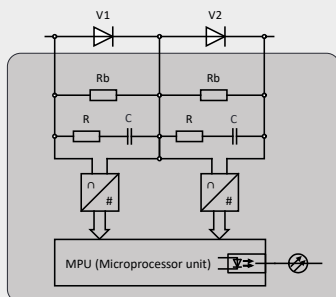

DIAGRAMS OF POWER PART.

Fixed rectifiers ("diode-diode")

15

600 V
750 V
825 V
800 - 2000 A
6-pulse rectification circuit

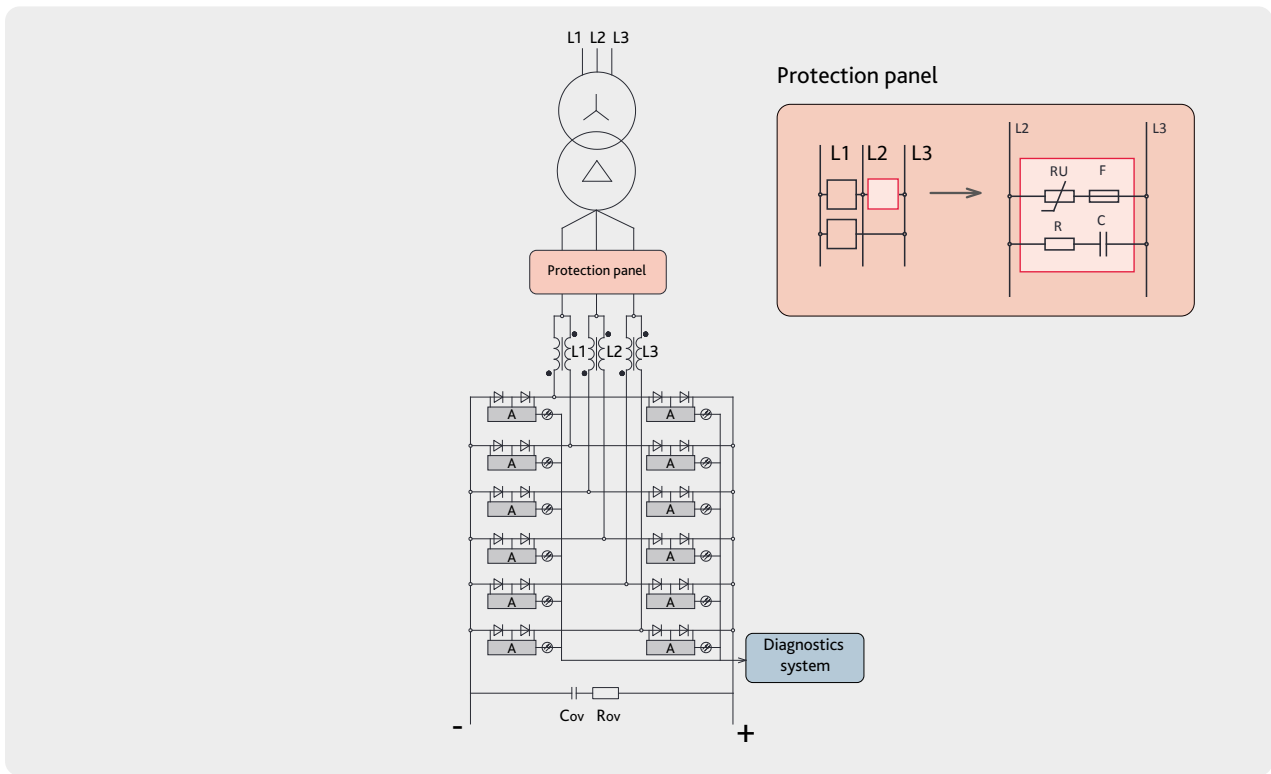

16

600 V
750 V
825 V
2500 - 4000 A
12-pulse rectification circuit

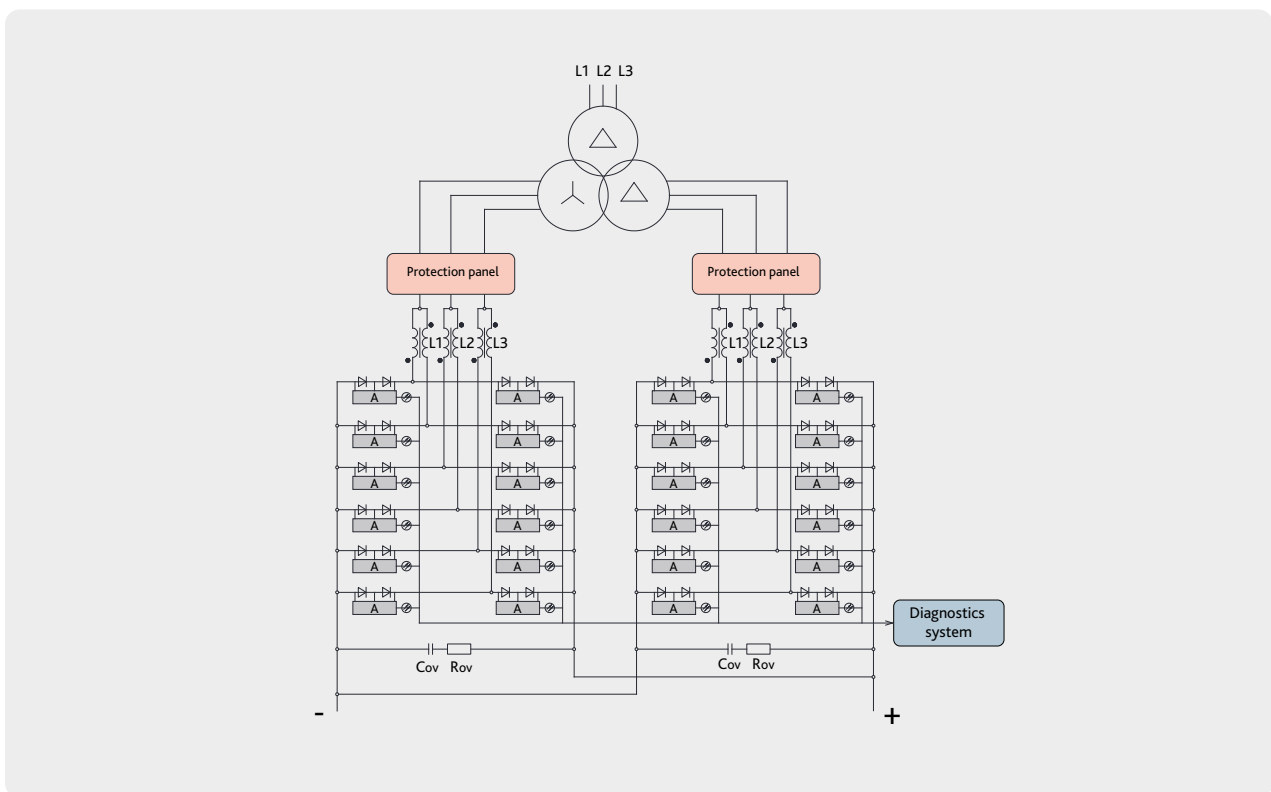

DIAGRAMS OF POWER PART.

Fixed rectifiers ("diode-diode")

17

1500 V
1650 V 2000 - 4000 A 12-pulse rectification circuit

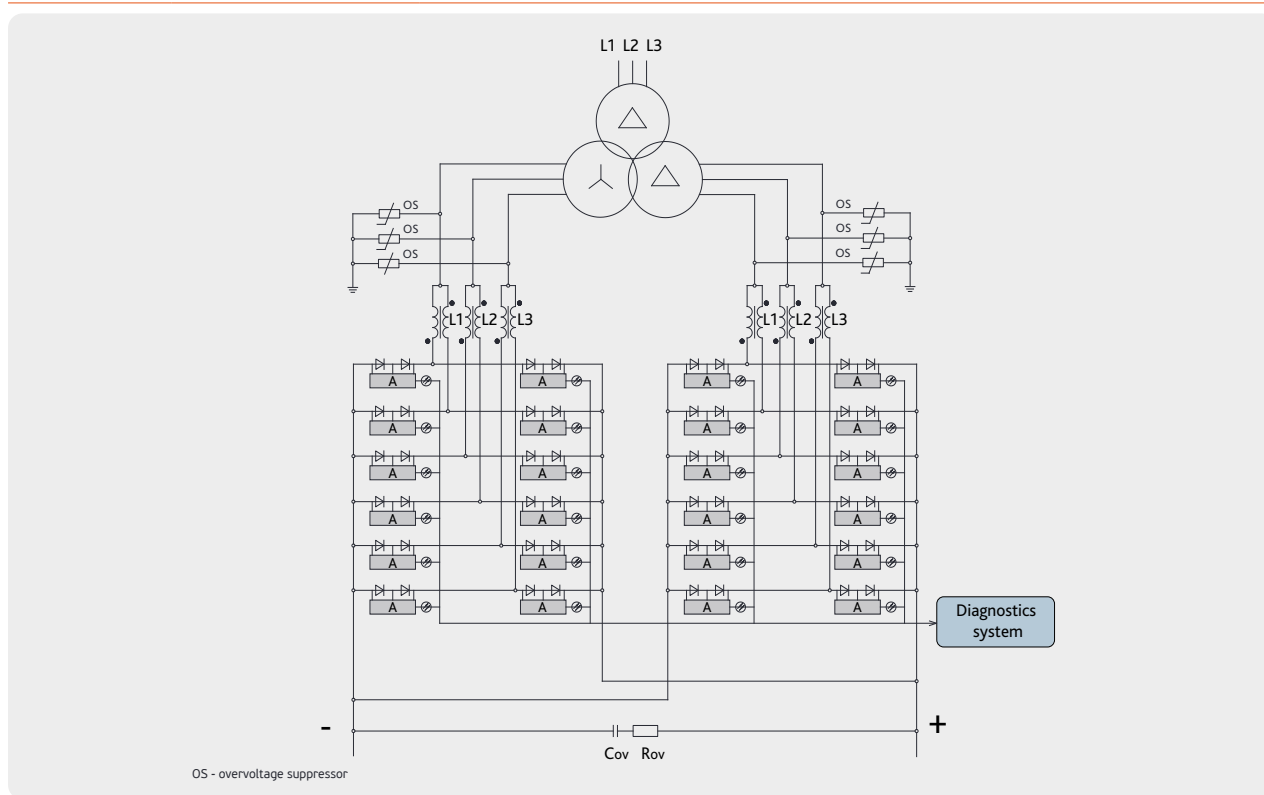

18

3000 V
3300 V 2000 - 3150 A 12-pulse rectification circuit

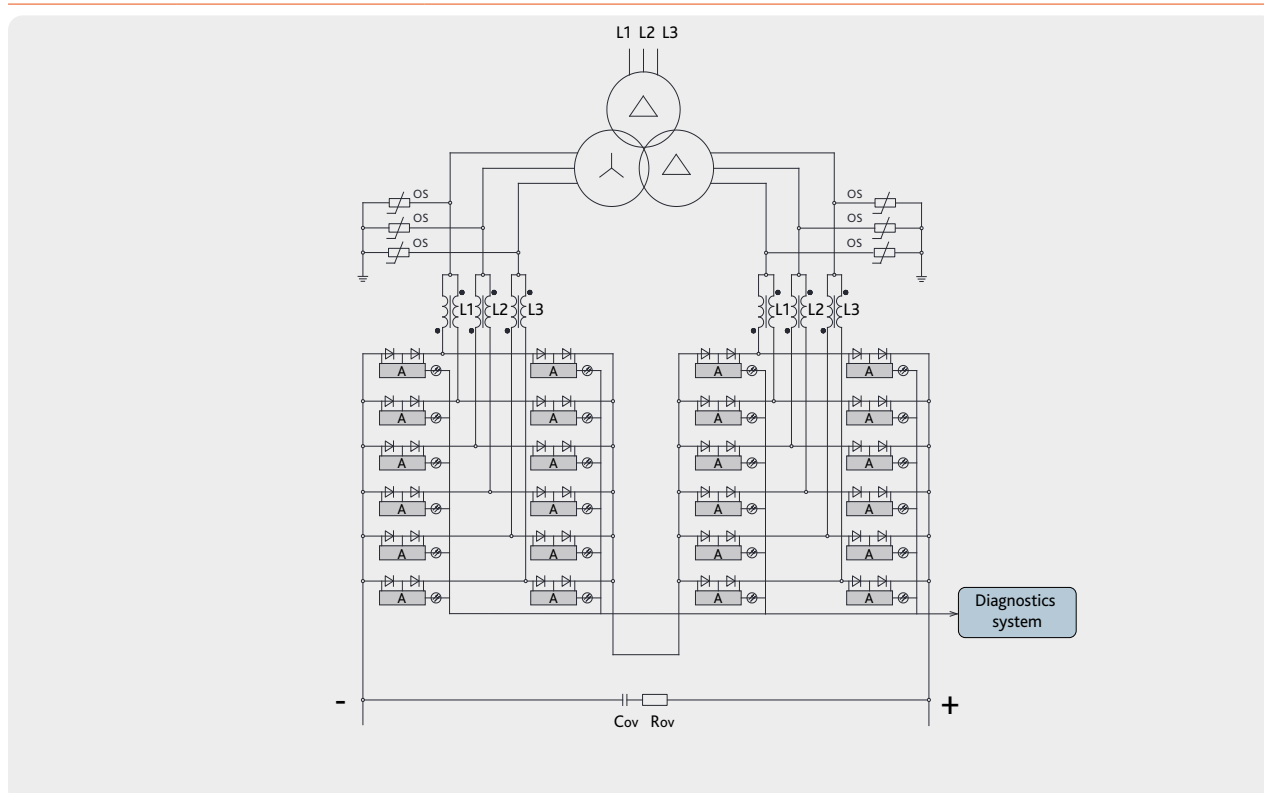

DIAGRAMS OF POWER PART.

Fixed rectifiers ("diode-fuse")

19

600 V
750 V
825 V

4000 - 8000 A

12-pulse rectification circuit

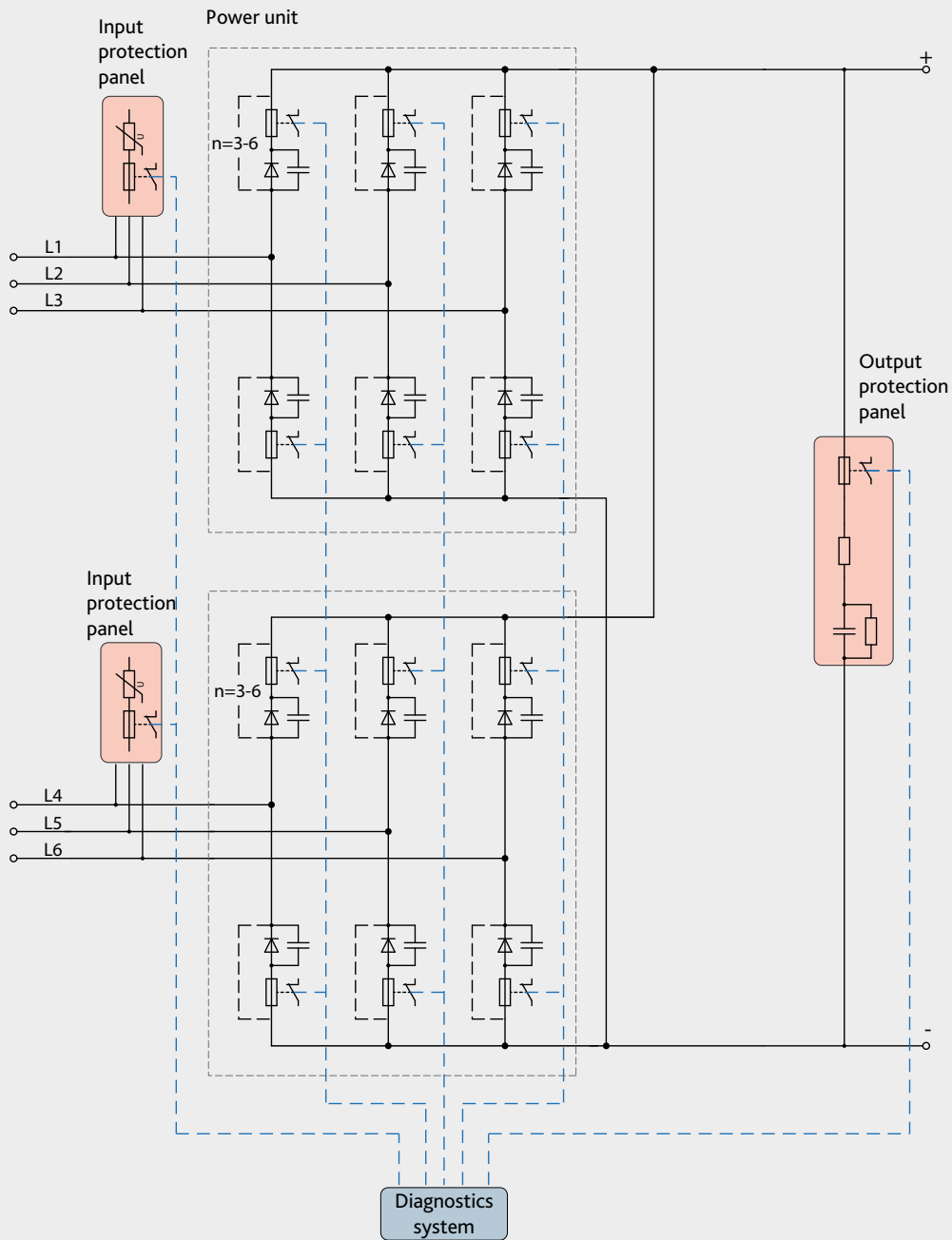

DIAGRAMS OF POWER PART.

Withdrawable rectifiers ("diode-diode")

20

600 V
750 V
825 V

1200 - 2000 A

VI duty class

6-pulse rectification circuit

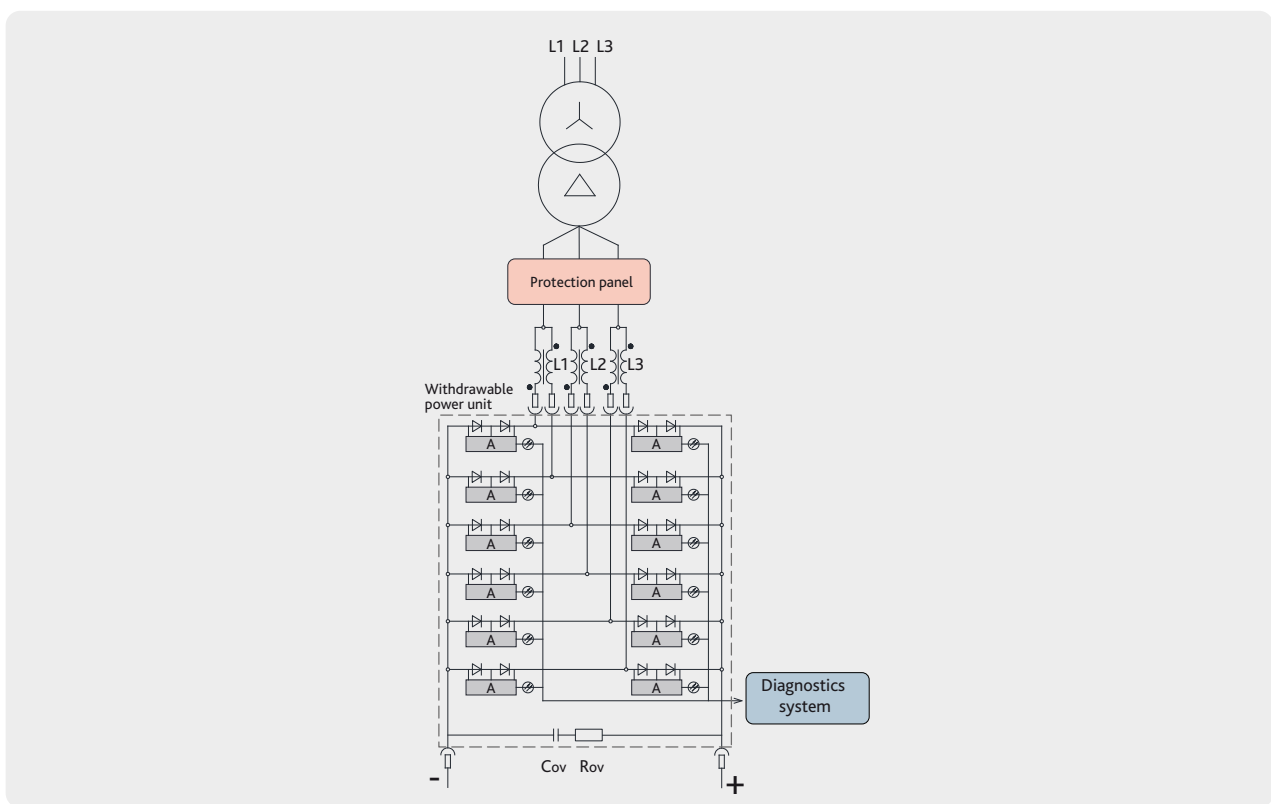

21

600 V
750 V
825 V

2500 - 4000 A

VI duty class

12-pulse rectification circuit

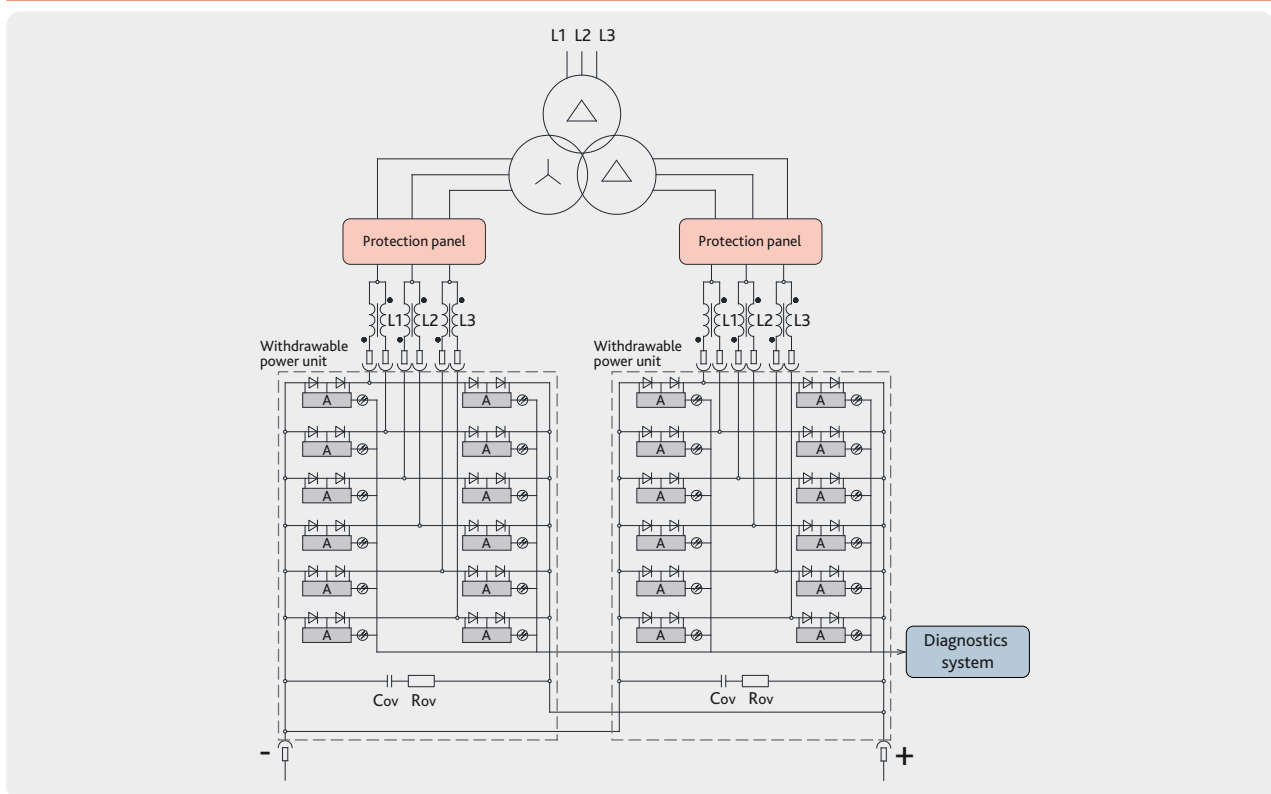

DIAGRAMS OF POWER PART.

Withdrawable rectifiers ("diode-fuse")

22

600 V
750 V
825 V
3000 - 4000 A
6-pulse rectification circuit

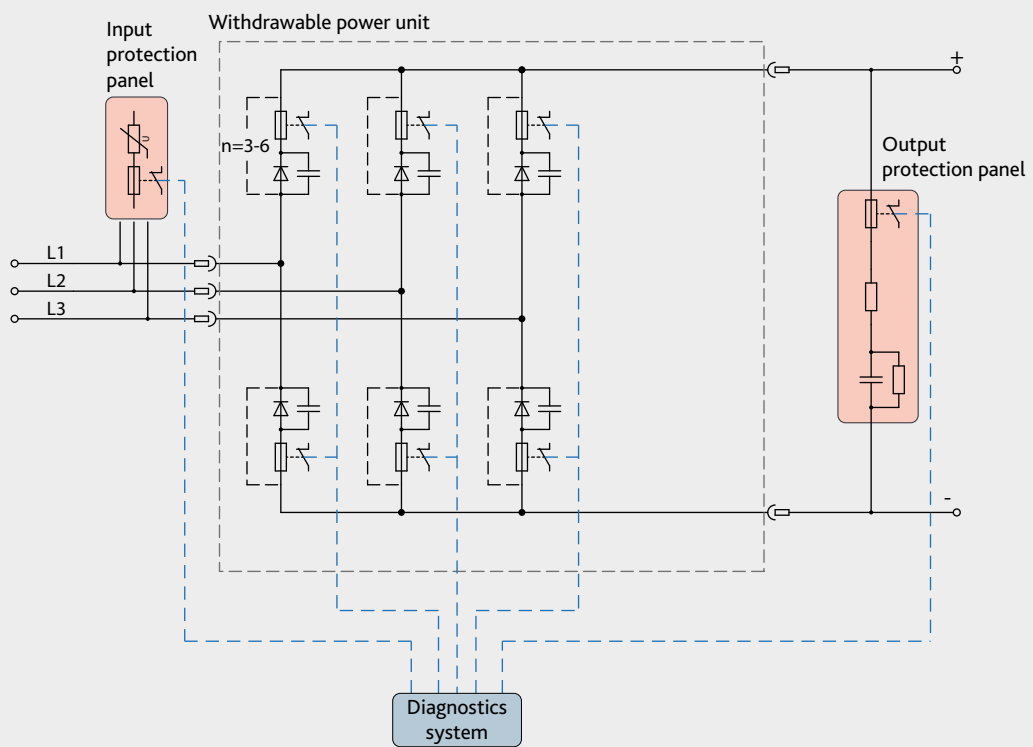

DIAGRAMS OF POWER PART.

Withdrawable rectifiers ("diode-fuse")

23

600 V
750 V
825 V

3000 - 4000 A

12-pulse rectification circuit

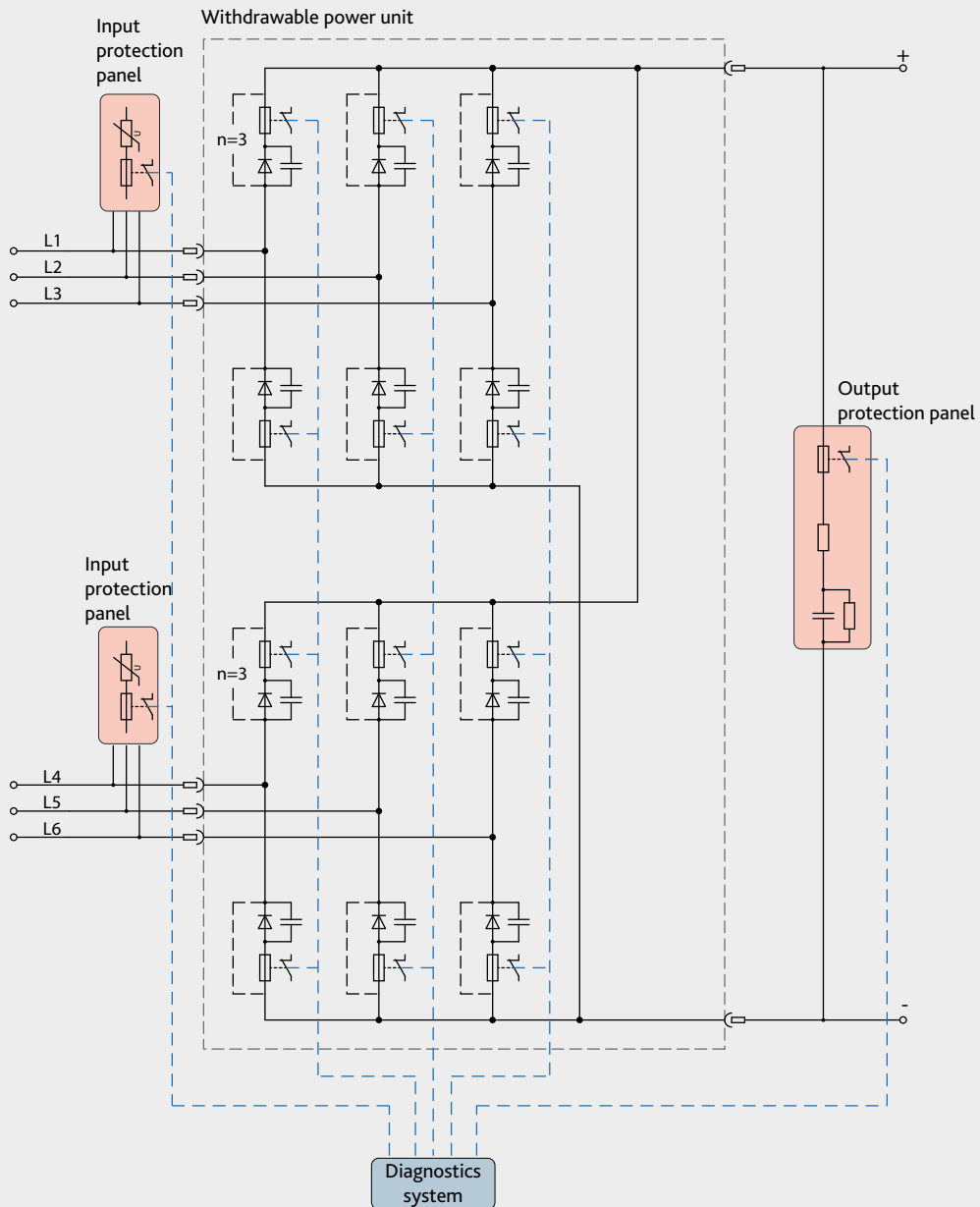

DIAGRAMS OF POWER PART.

Withdrawable rectifiers ("diode-fuse")

24

600 V
750 V
825 V

6000 - 8000 A

12-pulse rectification circuit

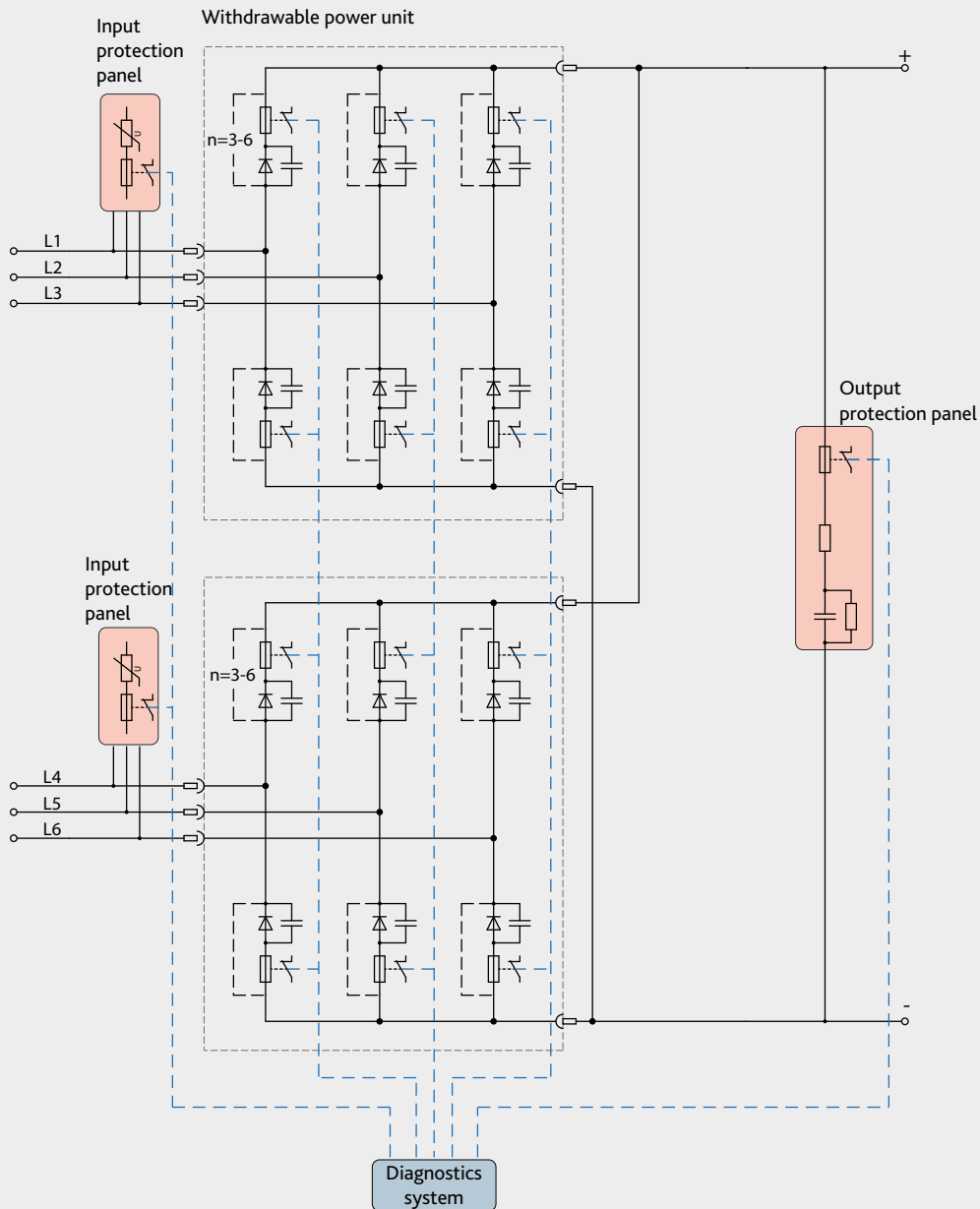

IMPLEMENTED PROJECTS

METRO

		Number of rectifiers
Sweden	Stockholm metro	5 units
Romania	Bucharest metro	3 units
Republic of Turkey	Izmir Metro	1 unit
Republic of Kazakhstan	Almaty Metro	26 units
Republic of Azerbaijan	Baku Metro	17 units
Republic of Uzbekistan	Tashkent Metro	39 units
Ukraine	Kyiv Metro	59 units
	Kharkiv Metro	12 units

CITY ELECTRIC TRANSPORT

Romania	Oradea, Medias, Vaslui	6 units
Republic of Poland	Lodz, Zgierz, Konstancin-Jezierna	18 units
Sweden	Stockholm	10 units
Republic of Madagascar	Antananarivo	4 units
Republic of Latvia	Riga	33 units
Republic of Moldova	Beltsy	12 units
Ukraine	Kyiv, Odesa, Kryvyi Rih, Lviv, Vinnytsia, Kramatorsk, Dnipro, Mykolaiv, Zaporizhzhia, Ivano-Frankivsk, Sumy	153 units
AR of Crimea	Kerch	3 units
Republic of Tajikistan	Dushanbe	28 units

RAILWAYS

Ukraine	Ukrainian Railways (Ukrzaliznytsia)	12 units
	Southern Mining Company (Kryvyi Rih), departmental railway	4 units
	Kryukovsky Railway Car Building Works (Kremenchuk)	1 unit
Republic of Poland	Polish Railway (PKP Energetyka S.A.)	1 unit
Georgia	Georgian railway	5 units
Republic of Kazakhstan	Kostanai Minerals JSC (Zhitikara)	1 unit



LLC PLUTON IC
4-B Lukasha M. st., office 1
Lviv, 79026 Ukraine

Tel./Fax:
+380 (61) 239-79-00
+380 (61) 239-79-01

E-mail: info@pluton.ua
www.pluton.ua

